

# 1/8TH SCALE OFFROAD NITRO BUGGY



## X3 SABRE

### FEATURES:

- LIGHT WEIGHT FRONT, REAR AND CENTER DIFFERENTIALS.
- COMPLETE SET OF LIGHT WEIGHT OUT DRIVES.
- 7075 CNC 5MM ALUMINIUM FRONT AND REAR SHOCK TOWERS.
- FULL TRAVEL FRONT AND REAR SUSPENSION.
- REDESIGN STEERING SYSTEM WITH ACKERMAN.
- SOLID CONSTRUCTED ARMS AND CAMBER LINKS.
- STEEL CAPTURED HINGE PINS.
- 7075 CNC ARM HOLDER AND TOE PLATE.
- 7075 CNC FRONT REAR CHASSIS BRACES.
- 7075 3MM LIGHTENED CHASSIS WITH COUNTERSUNK SCREWS.
- 7075 CNC ETCHED LEFT AND RIGHT LONG ENGINE MOUNT.
- VERSION 2 BIG BORE SHOCKS.
- TWO SETS OF SHOCK SPRINGS.
- COMPOSITE RADIO TRAY, ENCLOSED BATTERY AND RECEIVER BOX.
- FORWARD BATTERY COMPARTMENT FOR BETTER STEERING.
- 2 ANTI-CLOCKWISE SCREWS FOR FRONT AND REAR SHOCKS.
- FULL LIGHT WEIGHT CVA DRIVETRAIN.
- SPECIAL CAPPED CENTER DRIVELINE.
- SPECIAL CAPPED CENTER DRIVELINE.
- SMALL FRONT AND REAR GEAR CASE WITH SWAY BAR MOUNT.
- EQUIPPED WITH TWO SETS OF FRONT AND REAR SWAY BARS.
- ADJUSTABLE TURNBUCKLES AND LIGHTENED CAMBER LINKS.
- COMPLETE HIGH PERFORMANCE BEARING SET.
- FRONT AND REAR CHASSIS KICK UP (PATENTED).
- COMPOSITE STONE GUARDS AND REAR MUD DEFLECTORS.
- HIGH IMPACT DOWN FORCE WING.
- LIGHT WEIGHT INUP WHEELS WITH TIRES.
- HARD CHROME EFRA APPROVED 2028 IN-LINE PIPE AND HEADER.
- LIGHT WEIGHT FLYWHEEL AND SPECIAL MIXTURE ALUMINIUM 3 SHOES CLUTCH.
- CLEAR CAB FORWARD BODY FOR EXCELLENT HANDLING.
- 125CC FUEL TANK AND REMOVABLE TANK PLUG.
- INTEGRATED FUEL CLIPS (PATENTED) AND FUEL FILTER.
- CENTER DIFFERENTIAL WITH BRAKE AND GEAR SHROUD.
- SIDE LOADED CALIPER WITH RETURN SPRINGS.

### ADDITIONAL PARTS NEEDED

- ENGINE/MOTOR. ●BATTERIES.
- 2 CHANNEL RADIO. ●PAINT.
- GLOWPLUG. ●RC CAR FUEL (20%)
- GLOWPLUG IGNITOR.
- STARTER BOX OR STARTER.

### THIS IS NOT A TOY !

- DO NOT USE WITH CHILDREN YOUNGER THAN 16YEARS.
- PAINTED BODY NOT INCLUDED.

### 需另購物件

- 模型車用引擎. ●電池.
- 兩動作遙控器. ●車殼用塗料.
- 火星塞 ●模型引擎用燃油(20%)
- 火星塞點火夾.
- 起動馬達或起動台.
- 拆火星塞扳手.

### 本產品非玩具

- 16歲以下或兒童請勿玩用.
- 不包含塗裝車殼.

# HONG NOR

鴻諾企業有限公司

HONG NOR ENTERPRISE CO.,LTD.

5F NO.181-2, CHUNG HSING ROAD,

HSICHIH CITY, TAIPEI HSIEN,

TAIWAN, R.O.C.

TEL: 886 2-2694-0345

FAX: 886 2-2694-1632

www.hongnor-racing.com

圖示產品有可能為試樣品,包裝內容以實際出貨為準. 規格配備內容更改恕不另行通知.  
**MODEL SHOWN MAY BE PROTOTYPE AND MAY VERY SLIGHTLY FROM KIT. SPECIFICATIONS ARE SUBJECT TO CHANGE WITHOUT PRIOR NOTICE.**



**INCLUDED ITEMS**

附帶用品



7000wtg 5000wtg 2000 wtg  
差速器砂油



45wtg 55 wtg  
避震器砂油



1.5mm Allen Wrench  
1.5mm 內六角板手



2mm Allen Wrench  
2mm 內六角板手



2.5mm Allen Wrench  
2.5mm 內六角板手

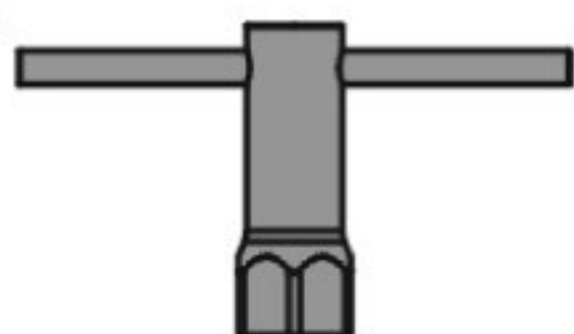

17mm Wheel Nut Tool  
輪胎拆除六角板手



Turnbuckle Wrench  
六角板手

**TOOLS NOT INCLUDED IN THE KIT**

需使用之工具 (另購)



Body Reamer  
車殼鑽孔器

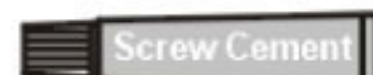

Screw Cement  
螺絲膠



Spray Paint  
模型用噴漆



Instant Cement  
3秒瞬間膠水



Curved Scissors  
彎頭剪刀



Cutter  
斜口鉗



Gear Grease  
齒輪潤滑油膏



Craft Knife  
美工刀



Needle Nosed Pliers  
尖嘴鉗



Precision Caliper  
游標卡尺



Screw Drivers  
螺絲起子

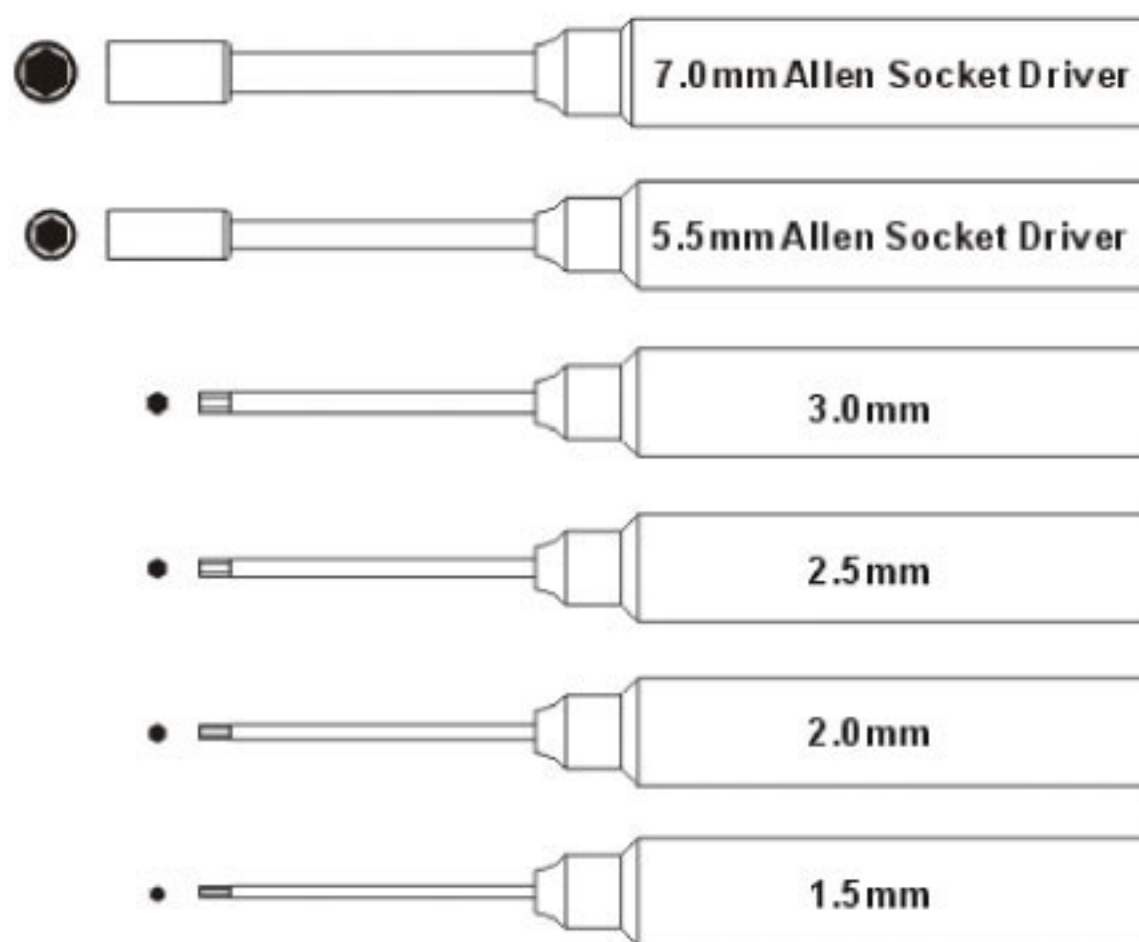

Allen Drivers  
六角起子



Flywheel Tool  
飛輪板手

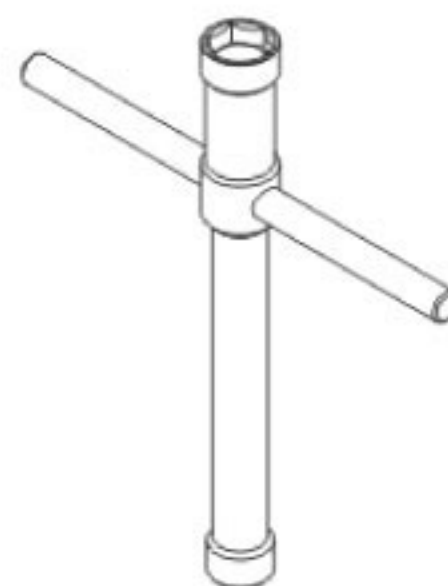

Cross Wrench  
中心螺帽板手

HONG NOR  
#339

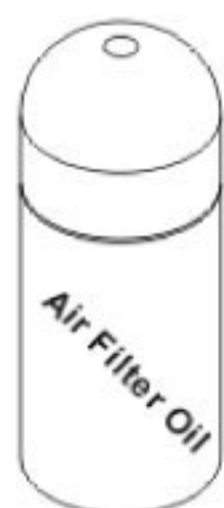

Air Filter Oil  
濾清器油

**Equipment Needed**

另購品



Transmitter  
遙控器



UM-3 Batteries  
For Transmitter  
(8pcs)  
遙控器用  
3號乾電池 (8顆)



Fuel Bottle  
加油瓶



Glow Fuel  
模型用燃油



Glow Igniter  
可充電式點火夾

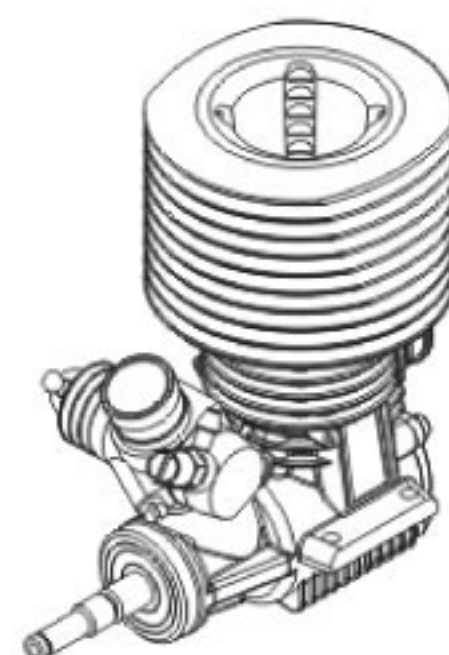

.21 Engine  
21級引擎



Servo  
伺服器



Receiver Switch  
接收器

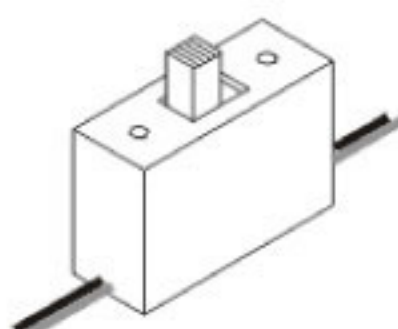

Receiver Switch  
接收器開關

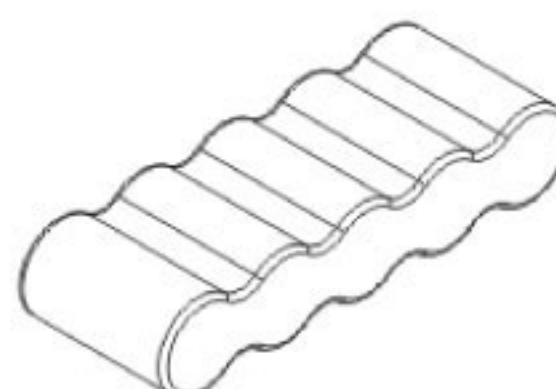

5-cell 6V Receiver Pack  
5顆裝6V電池包

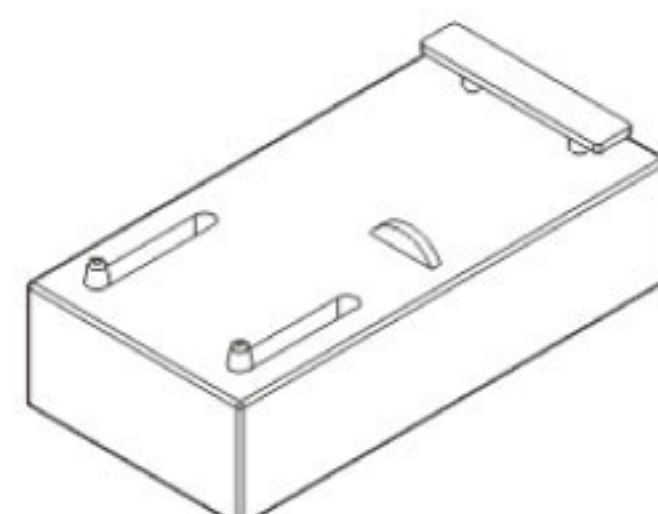

Starter Box  
起動台





# IMPORTANT-READ THIS BEFORE RUNNING

重要！操作前請先閱讀

## 1. Before Starting

啟動前

- ◎ **Please read manual carefully! (With a parent, guardian or a responsible adult if necessary).**  
請仔細閱讀說明書, (如有必要, 須有家長, 監護人, 或其他成年人陪同)。

## 2. While Operating

當操作時

- ◎ **Any running area you choose must be dry. Do not run vehicle near any water or wet areas.**  
請在乾地上操控車子。並請勿操控車子於水池或溼地旁。
- ◎ **Do not run on public streets. It is very easy to have the car run over or be damaged by hitting the curb.**  
勿在大街上操控車子, 因為它很容易被行駛中的車輛碾過或碰撞而有所損傷。
- ◎ **Do not operate the car in tight confined places. The vehicle is very fast and will easily hit something.**  
勿在空間狹窄的地方操作; 因為它的速度快很容易碰撞周圍物件。
- ◎ **Do not run near people or animals. The car is very fast and could easily hit someone if you are not an expert driver.**  
勿操作車子於人群或動物旁; 如您不是專業人士操作, 他們都可能發生危險。
- ◎ **Do not operate the car at night. You will not be able to drive it safely.**  
勿在晚上操作模型車, 因可能視線不佳而導致它發生碰撞。

## 3. Before Operating

操作前檢查

- ◎ **Make sure that all screws and nuts are properly tightened.**  
確認螺絲與螺帽有無鬆動。
- ◎ **Always use fresh batteries for your transmitter and receiver before running the car. If the radio does not have full control of the car with steering, throttle and brake. Do not run it until corrected. Failure to correct this will result in possible injury and damage to the car or property.**  
**We strongly recommend using a failsafe.**  
操作前請先換上全新的電池, 如果電量不足時, 將不能完全控制車子的油門及剎車或行進方向。此刻請立即停駛, 並換上全新電池。如果不立即改善, 可能將導至失控而使人體受傷或車子受損。我們極力建議裝配"防失控裝置"在您的車上。
- ◎ **Please confirm the steering and throttle is at neutral position.**  
請確認油門位於中立點位置。

## 4. Check Your Vehicle After Running

操作後注意事項

- ◎ **Turn OFF receiver first, then turn OFF transmitter. This will prevent the car from losing control.**  
先關閉接收機電源, 再關閉遙控器電源, 如此以避免遙控車失控產生爆衝。
- ◎ **After running radio controlled car, it is necessary to perform routine maintenance.**  
遙控車跑完之後需要進行保養。

## 5. Cautions for Safety

安全注意事項

- ◎ **If your model does not operate correctly, stop it and find the cause.**  
如果遙控車有不正確表現, 請停止操作, 並立即檢查原因。
- ◎ **Keep hands and tools away from parts in action.**  
勿用手碰觸運轉中的零件。

**WARNING: After each run, the model is hot, beware of getting burned.**

警告 每次行駛都將導致引擎在高溫中, 請勿用手觸摸引擎, 以免燙傷。





# IMPORTANT-READ THIS BEFORE RUNNING

Running nitro kit is fun and easy, but to make this a safe and good experience you must observe a few rules. This kit is extremely fast, easily over 65KPH, and can seriously injure someone if you are not careful.

## 1. Where to run car?

- ⊙ Any running area you choose must be dry. Do not run car near any water or wet dirt.
- ⊙ Do not run on public streets. It is very easy to have the car run over or be damaged by hitting the curb.
- ⊙ Do not operate the car in tight confined places. The car is very fast and will easily hit something.
- ⊙ Do not run near people or animals. The car is very fast and could easily hit someone if you are not an expert driver.
- ⊙ Due to noise, you will want to consider the surrounding area when operating the car.
- ⊙ Do not operate the car at night. You will not be able to drive it safely.
- ⊙ Do not operate the car indoors. Engine exhaust fumes are dangerous.

## 2. Glow Fuel

- ⊙ Glow fuel is poisonous!
- ⊙ Glow fuel is flammable!
- ⊙ Do not leave in fuel bottle with lid off at any time.
- ⊙ Do use any fuel other than glow fuel in this engine.

## 3. First Time Starting the Engine

### Caution!

**When starting the engine make sure the following is observed.**

- ⊙ Set engine Master needle to 3 turns (rich setting)
- ⊙ Do not do this alone, get an experienced friend to help for the first time.
- ⊙ Fill fuel tank, try not to spill fuel. Do not spill fuel on receiver.
- ⊙ Hold car off the ground, so it will not runaway when it first starts.
- ⊙ Turn on the radio and check the linkage before starting engine.
- ⊙ Turn on car receiver battery switch.
- ⊙ Always have an air filter on the carburetor to keep dirt out.

## 4. Engine Break-in

- ⊙ See section.

## 5. Emergency Engine Stopping

- ⊙ Remove air filter and cover carb. intake.
- ⊙ Squeeze fuel line and hold until engine stops.
- ⊙ With a rag, cover exhaust outlet.

## 6. Storing Car After Running

- ⊙ Remove fuel from tank and fuel lines
- ⊙ Turn off radio in the car
- ⊙ Put a few drops of after run in the engine to keep it from rusting.
- ⊙ Clear oil and dirt from chassis with a degreaser.

## 7. Precautions

- ⊙ This kit is not a toy. Always run car with a second person as a spotter and pitman.
- ⊙ Hot Parts-The pipe, manifold, engine and head are very hot and will cause burns.
- ⊙ Rotating Parts-Keep hands away from the drive train, wheels, and engine when engine is running.
- ⊙ Radio-Check battery life before running the car. The radio does not have full control of the car with steering and/or throttle/brake, do not run until corrected. Failure to correct this will result in possible injury and damage to the car or property. We strongly recommend using a Failsafe.
- ⊙ Glow fuel-Do not leave the glow fuel unattended with the lid off. Fuel contains Methanol and Nitro Methane and is flammable and poisonous.

**Store fuel in cool ventilated location.**

**Refer to the glow fuel label for additional precautions.**

- ⊙ Fuel tank in the car-Never store fuel in car tank, it will ruin the engine if left in tank.
- ⊙ Always turn off the car BEFORE turning off the radio.
- ⊙ DAMAGE DUE CAR RUN AWAY IS NOT A WARRANTY ISSUE .

**IF YOU DO NOT BREAK-IN ENGINE CORRECTLY, AT LOW-MID RPM, YOU WILL BREAK THE CONNECTING ROD!**

**FAILURE TO READ AND FOLLOW BREAK-IN ENGINE INSTRUCTIONS WILL VOID WARRANTY!**



# PARTS REFERENCE 零件圖

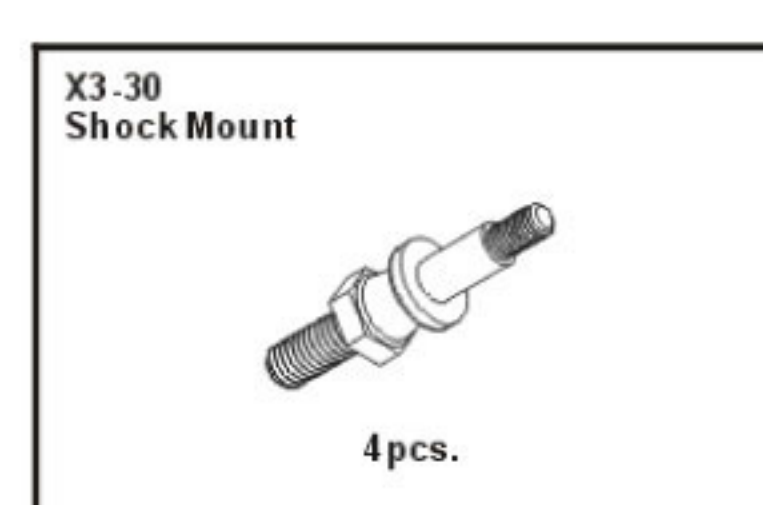
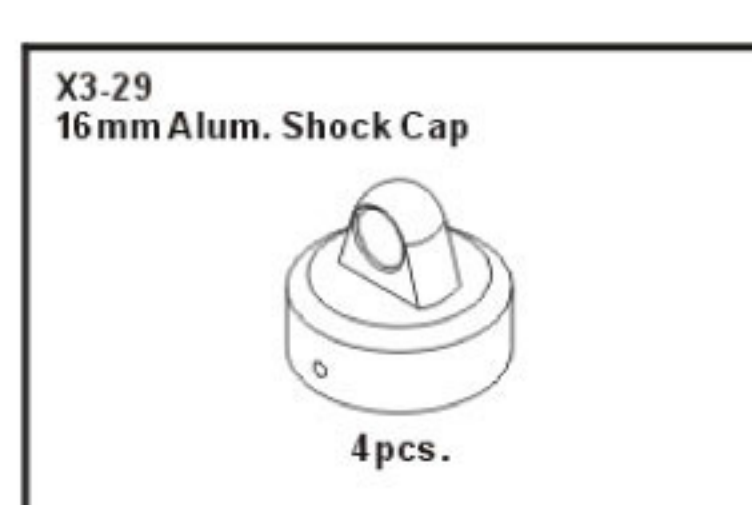
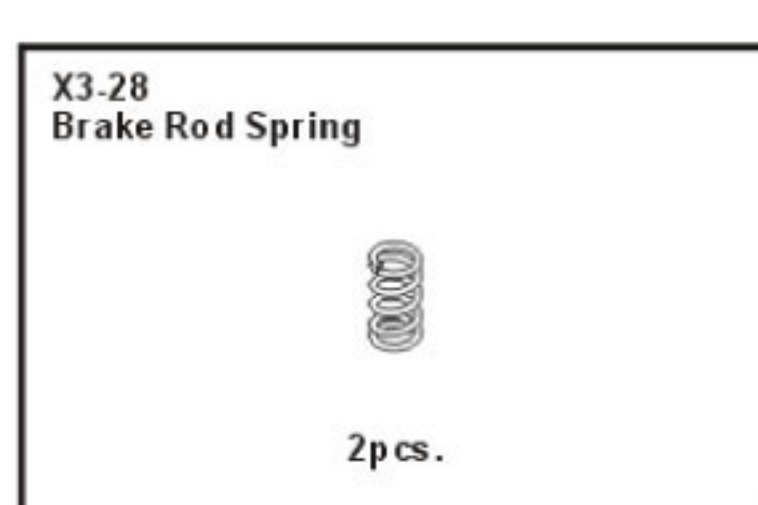
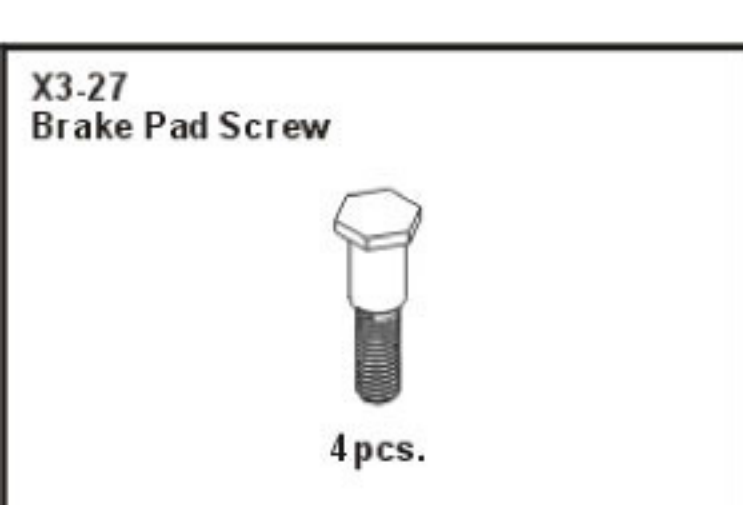
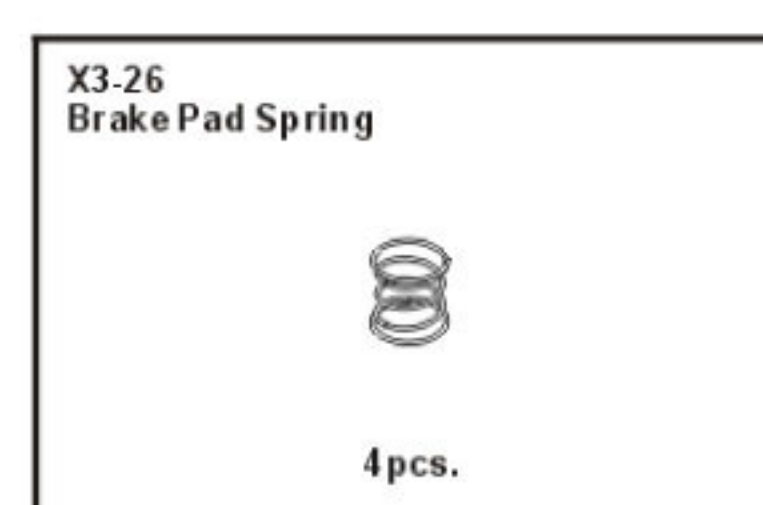
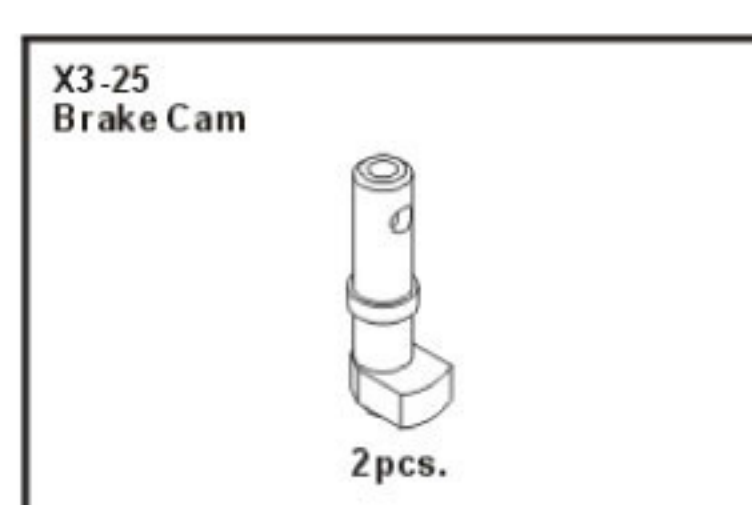
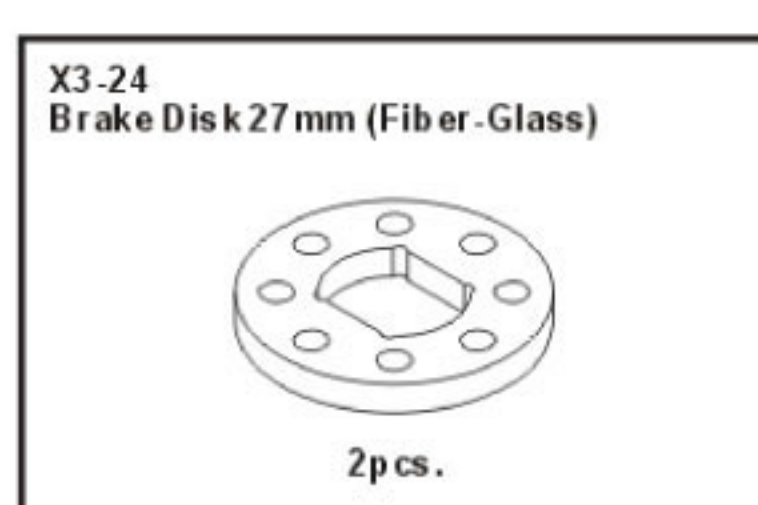
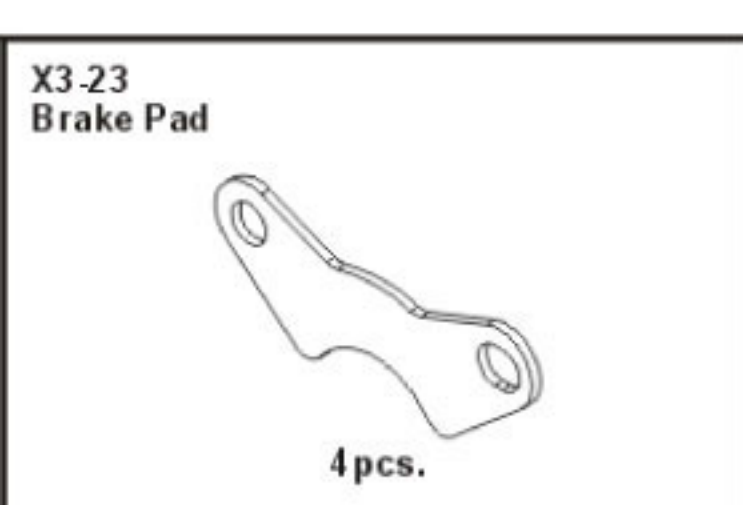
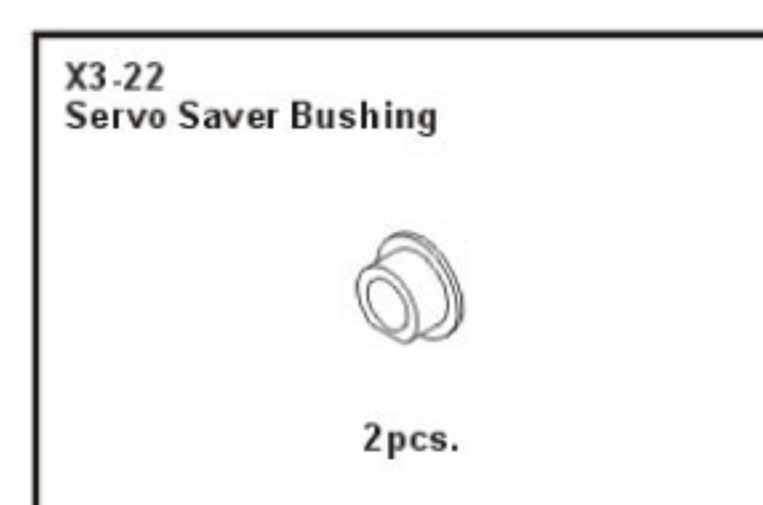
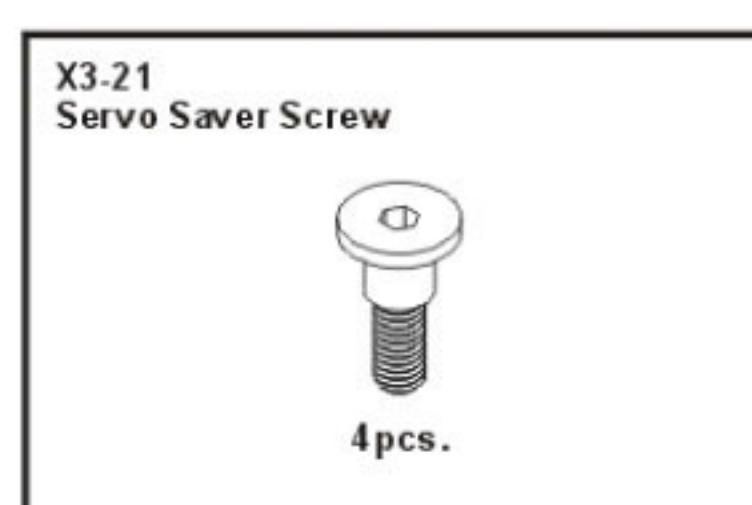
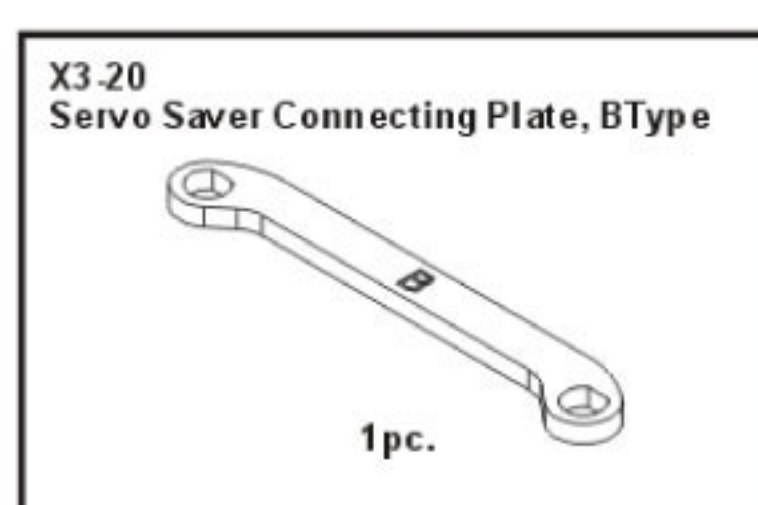
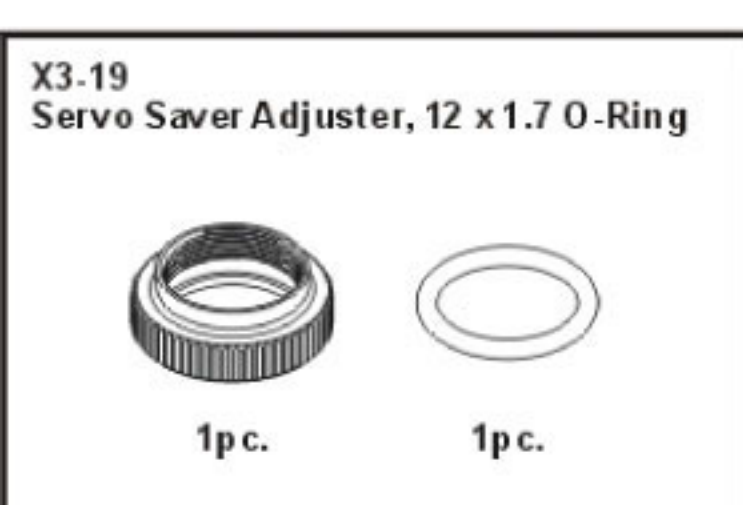
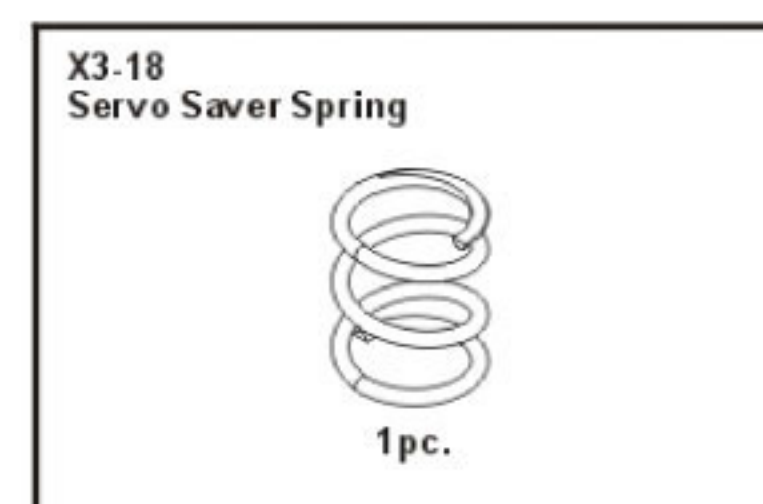
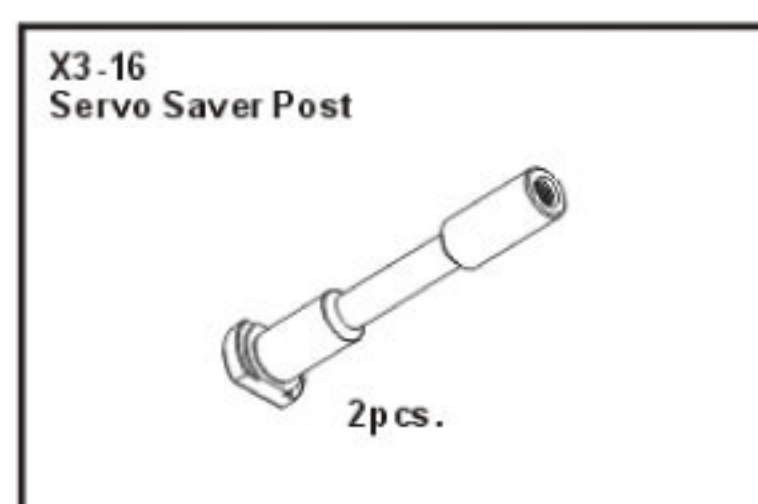
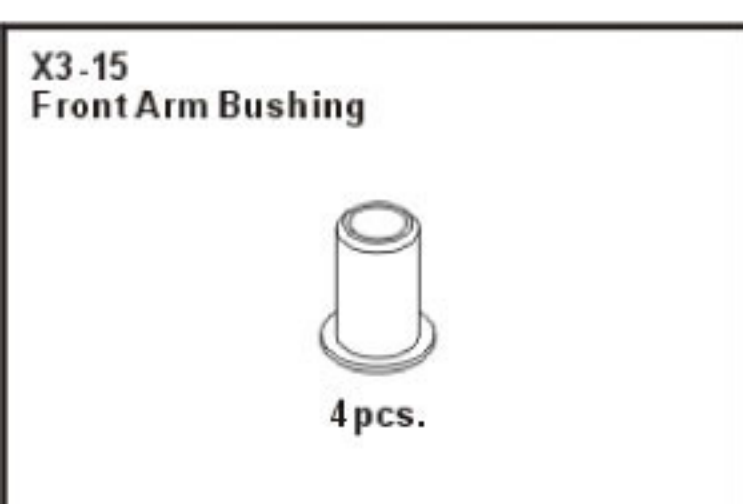
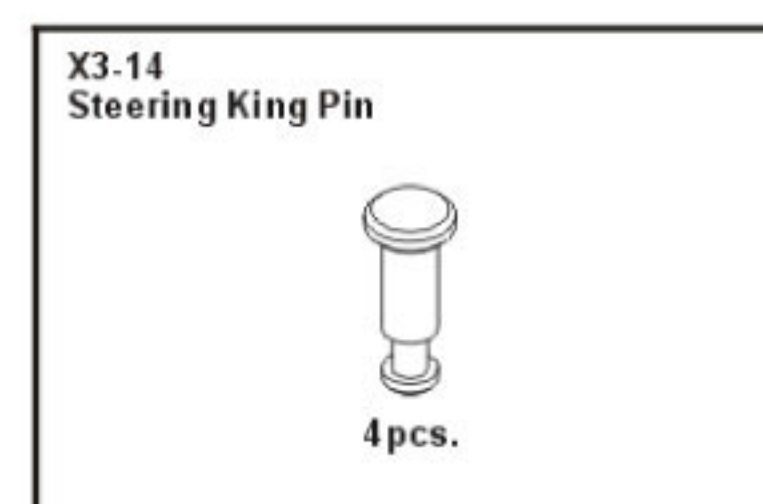
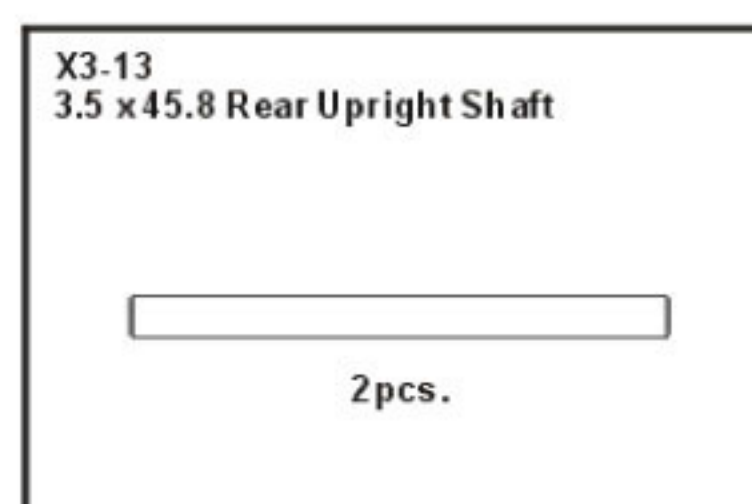
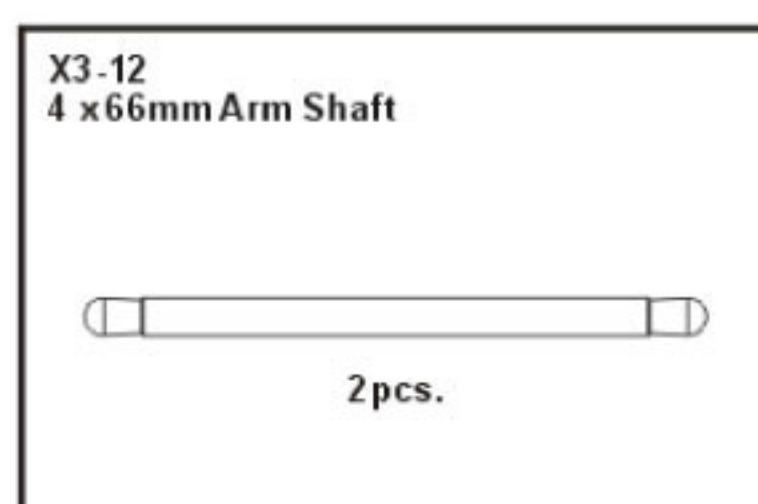
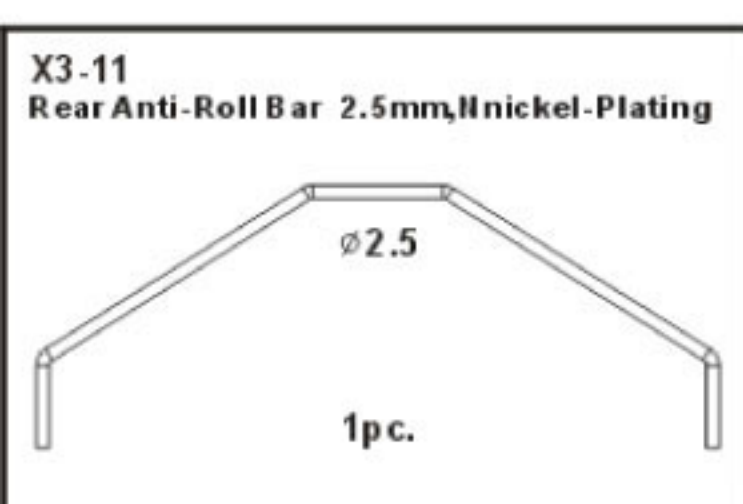
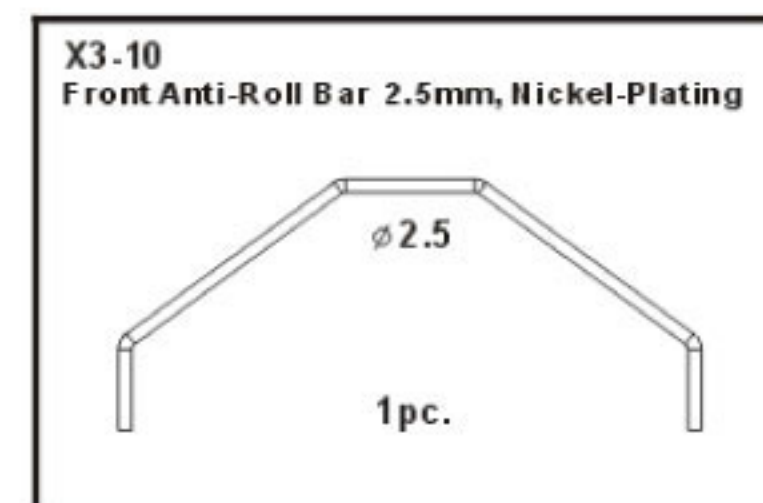
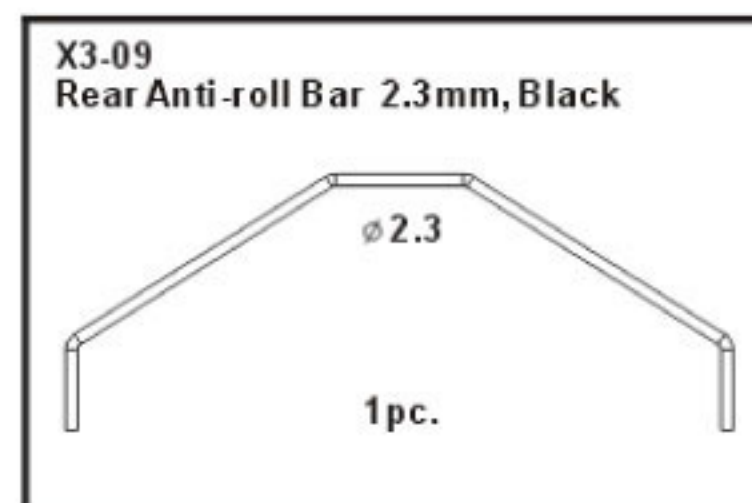
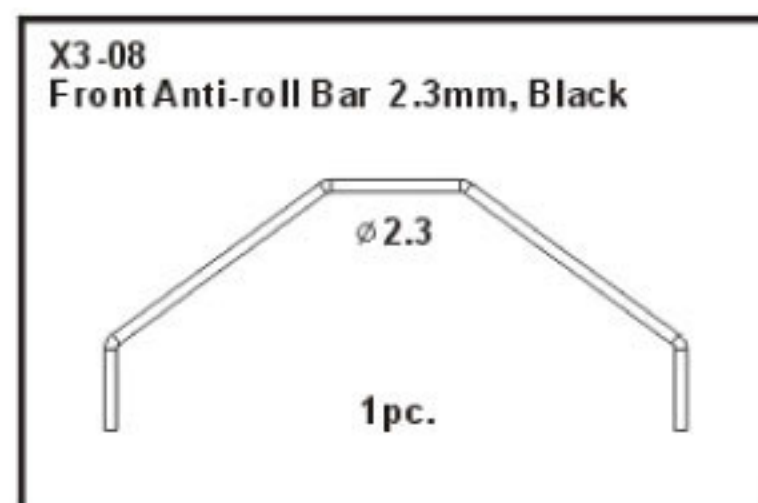
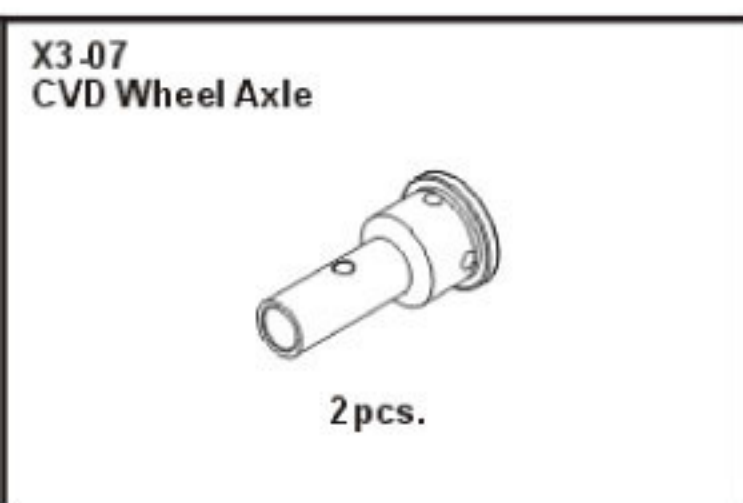
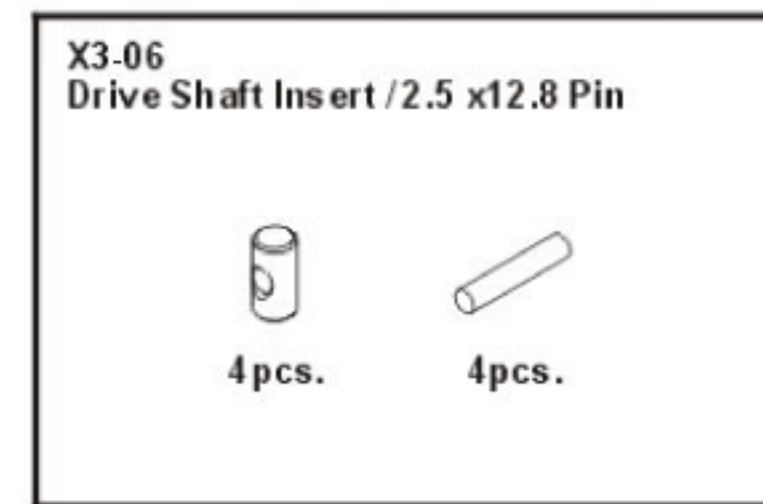
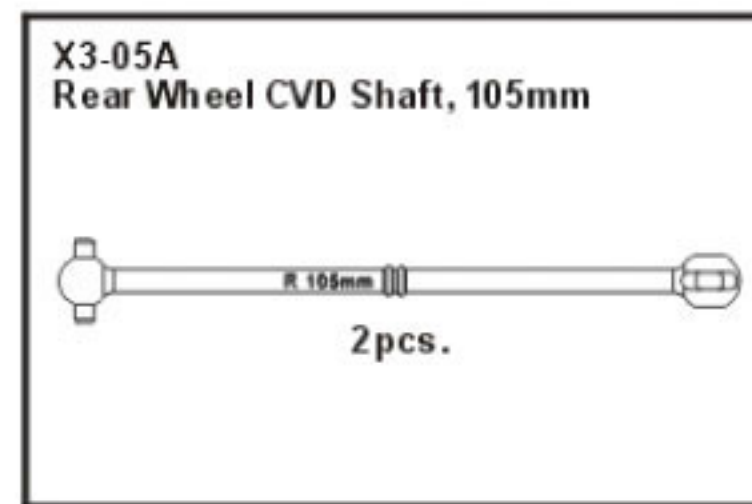
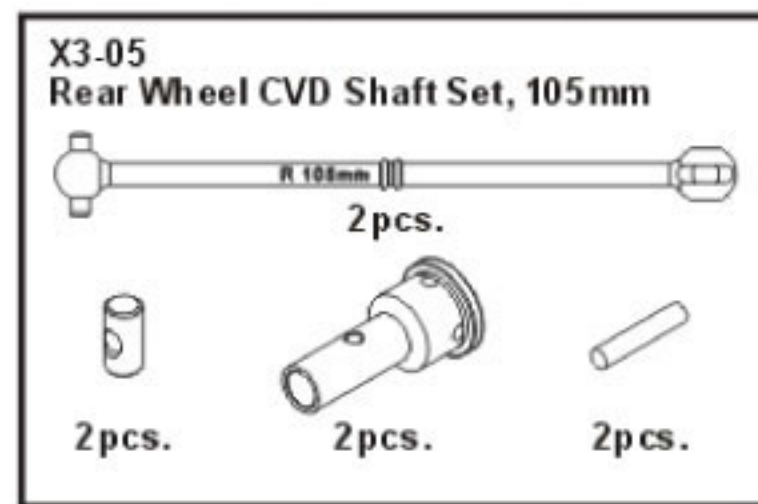
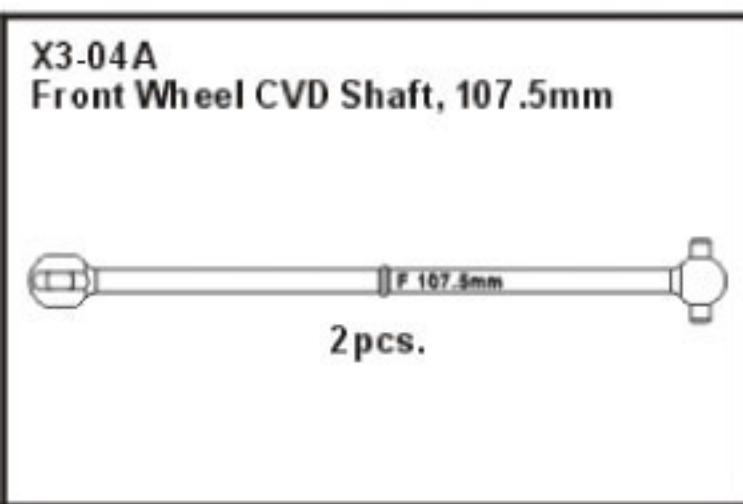
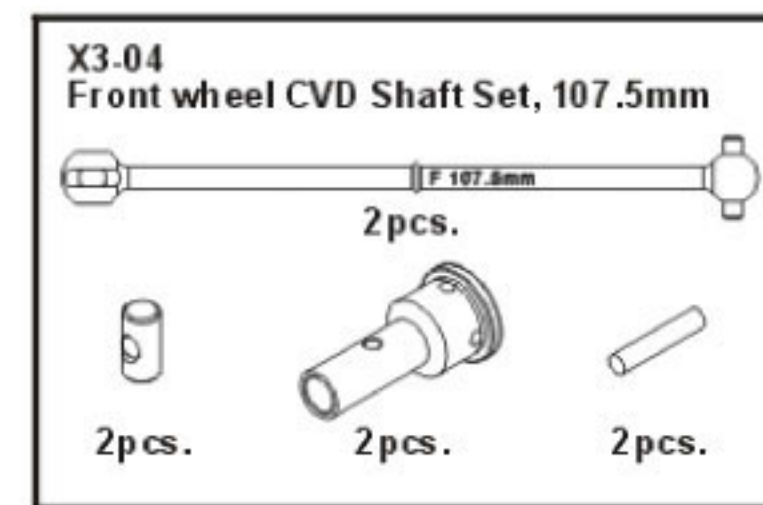
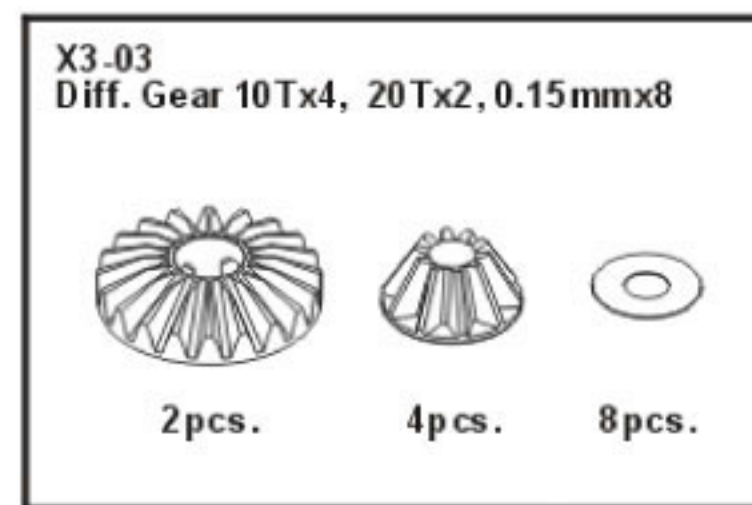
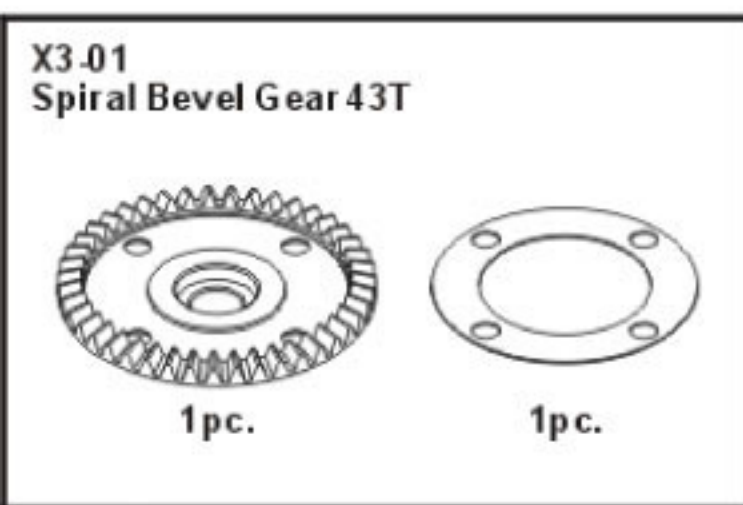



# PARTS REFERENCE 零件圖

**X3-31**  
7x8.5mm Ball & Socket



4pcs.

**X3-32**  
7x12mm Ball & Socket



4pcs.

**X3-33**  
Hex 4mm Ball & Socket



2pcs.

**X3-34**  
2.5x11.8 Pins



10pcs.

**X3-35**  
2.5x12.8 Pin



10pcs.

**X3-36**  
Brake Linkage Rod 1.8 x 95mm



1pc.

**X3-37**  
Engine Mount L.R (Black)

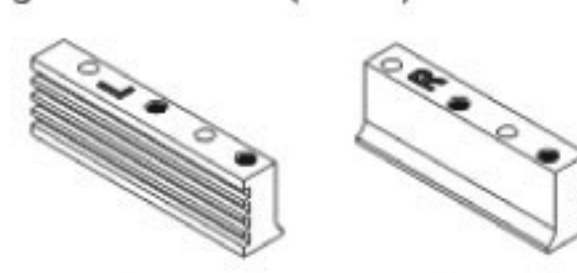

1pc. 1pc.

**X3-38**  
Diff Gasket 31x20x0.3

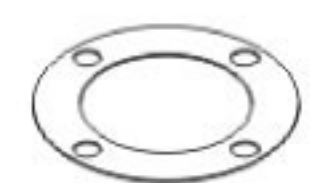

3pcs.

**X3-39**  
4x8mm Engine Mount Screw



4pcs.

**X3-40**  
4x10mm Set Screw, Round Head



4pcs.

**X3-41**  
X3S PC Body, Clear

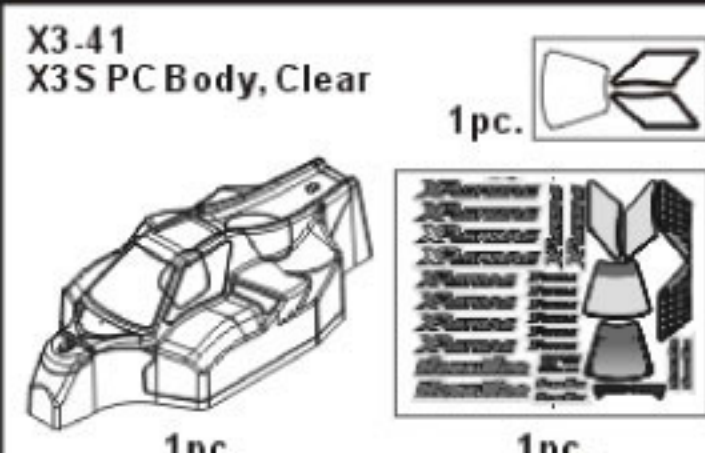

1pc. 1pc.

**X3-42**  
X3S Fuel Tank



1pc.

**X3-43**  
Diff. Case (F&R)

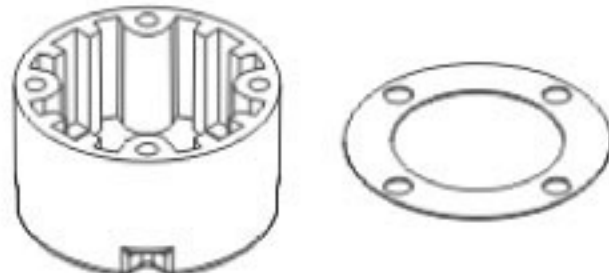

1pc. 1pc.

**X3-44**  
Gear Case

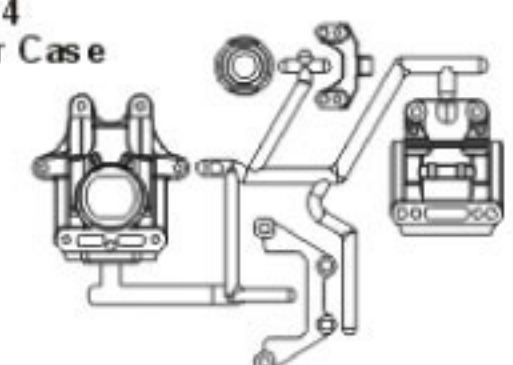

1pc.

**X3-45**  
Front Lower Arms L,R

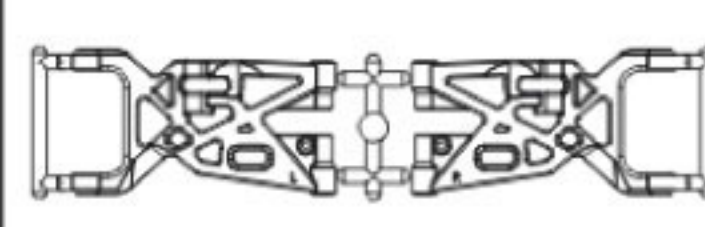

1pc.

**X3-46**  
Suspension Eccentric Bushing

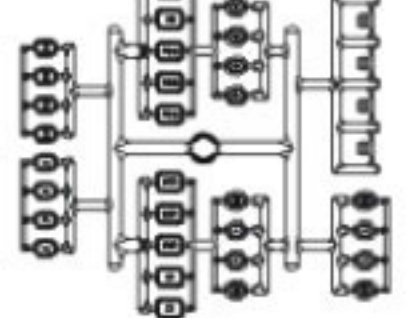

1pc.

**X3-47**  
Steering Knuckle Arm L,R

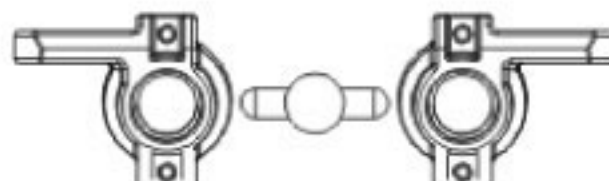

1pc.

**X3-48**  
Front C Hub L,R

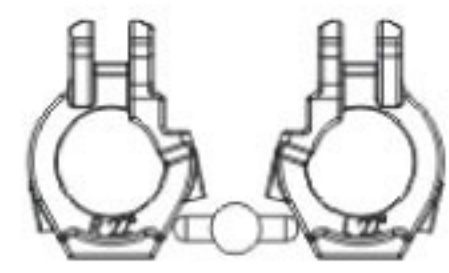

1pc.

**X3-49**  
Body Post/Center Brace

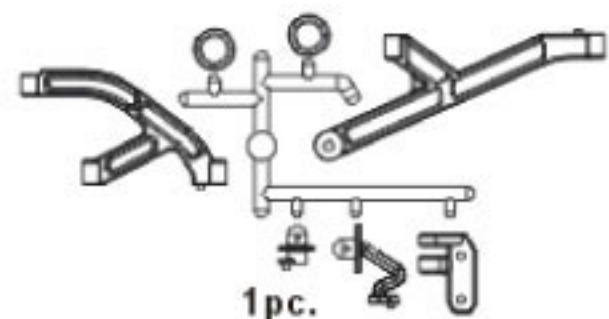

1pc.

**X3-50**  
Plastic Rod End

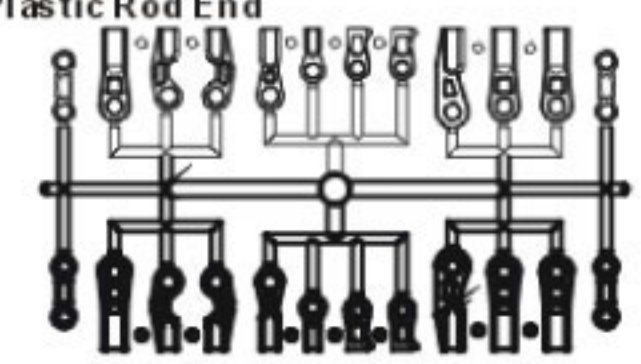

1pc.

**X3-51**  
Servo Saver Set/Front Top Deck

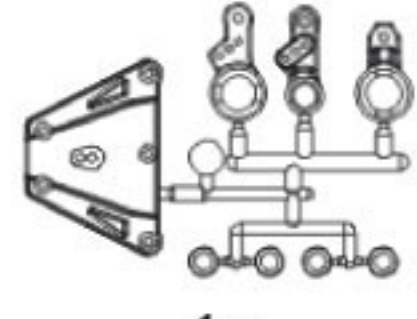

1pc.

**X3-52**  
Front Bumper/Rear Mud Deflectors

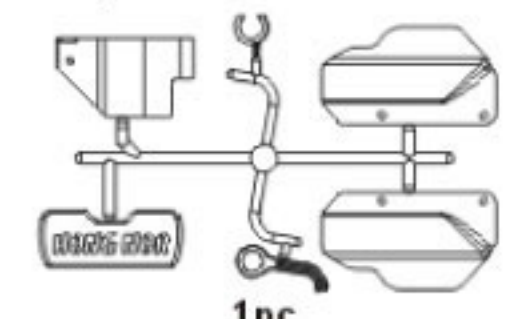

1pc.

**X3-53**  
Rear Lower Arms L,R

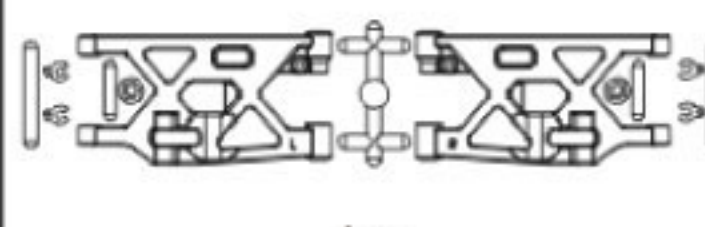

1pc.

**X3-54**  
Rear Hub Carrier L,R

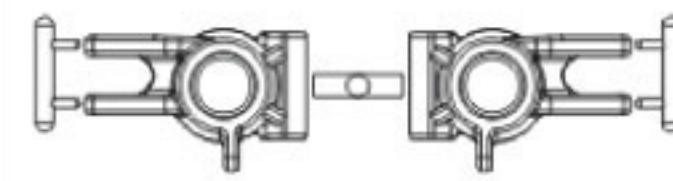

1pc.

**X3-55**  
Rear Wing Mount

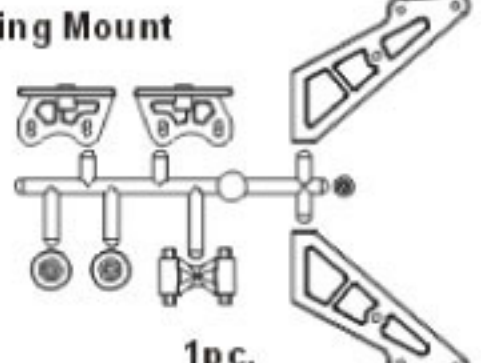

1pc.

**X3-56**  
Center Diff Holder Part

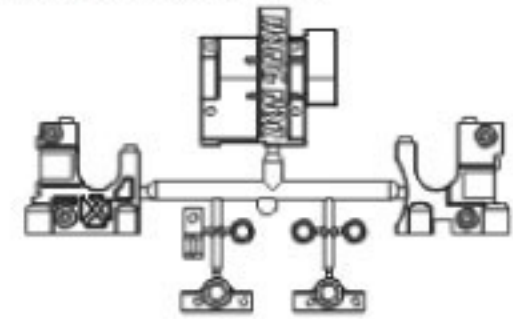

1pc.

**X3-57**  
Side Guard L,R

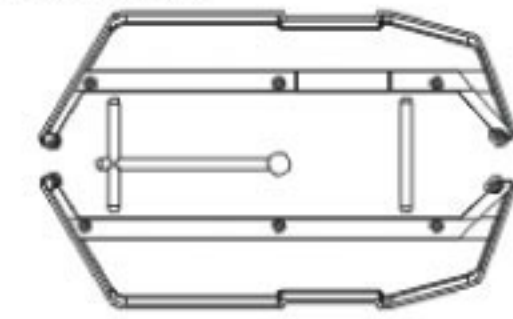

1pc.

**X3-58**  
Receiver/Battery Box

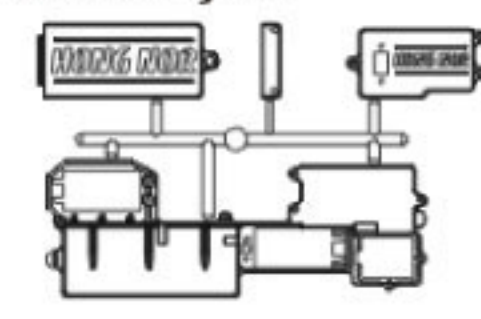

1pc.

**X3-59**  
Throttle/Steering Level Set

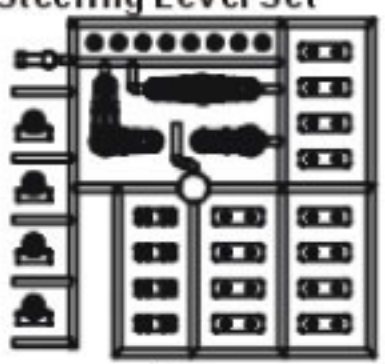

1pc.

**X3-60**  
1/8 Air Filter /Foam

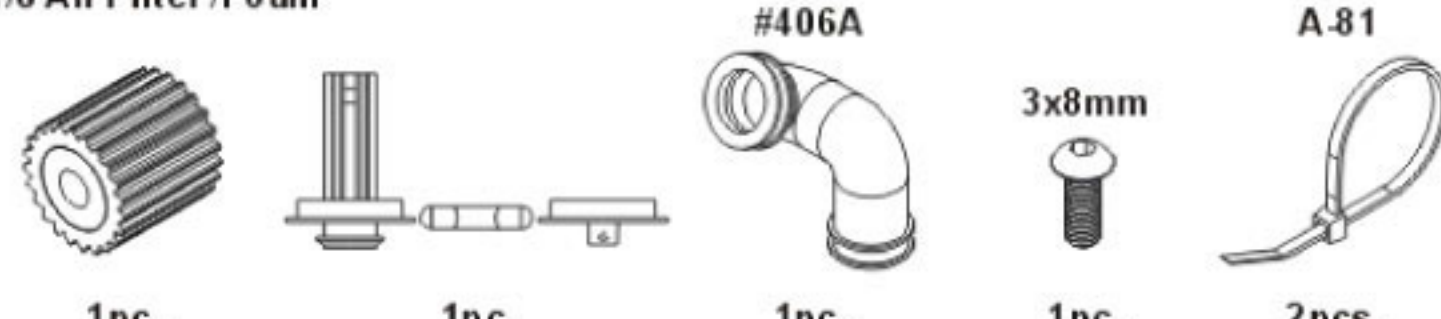

1pc. 1pc. 1pc. 1pc. 2pcs.

**X3-60A**  
Air Filter Foam

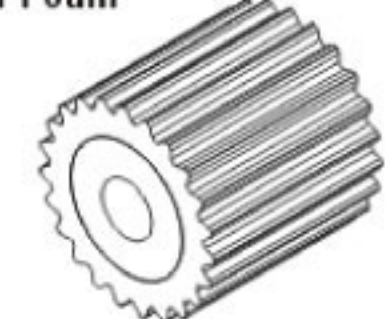

1pc.



# PARTS REFERENCE 零件圖

**X3-61**  
8x14 Ball Bearing











4 pcs.









**X3-62**  
13x20 Ball Bearing





4 pcs.

**X3-63**  
X3S Screw Bag

	3x5	10 pcs.		3x15	12 pcs.
	3x8	2 pcs.		3x18	10 pcs.
	3x10	8 pcs.		3x20	2 pcs.
	3x12	8 pcs.		3x22	2 pcs.

	3x25	2 pcs.		3x8	10 pcs.
	3x35	2 pcs.		3x10	7 pcs.
	4x15	1 pc.		3x15	6 pcs.
	4x18	4 pcs.		3x16	2 pcs.

	3x35	4 pcs.		4x12	8 pcs.
	4x16	4 pcs.			

**X3S-01**  
CNC 7075-3mm Lightweight Chassis

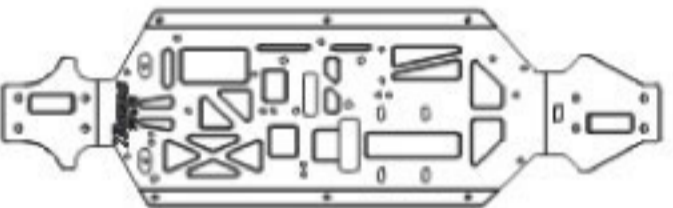

1 pc.

**X3S-02**  
CNC 7075-5mm Front Shock Tower



1 pc.

**X3S-03**  
CNC 7075-5mm Rear Shock Tower



1 pc.

**X3S-04**  
Diff. Cap Joint (Lightweight)





2 pcs.

**X3S-05**  
CNC 7075 Chassis Brace (Front/Rear)





1 pc. 1 pc.

	3x12	1 pc.		3x10	4 pcs.		3mm	5 pcs.
---	------	-------	---	------	--------	---	-----	--------

**X3S-05A**  
CNC 7075 Chassis Brace (Front)





1 pc.

	3x12	1 pc.		3x10	2 pcs.		3mm	3 pcs.
---	------	-------	---	------	--------	---	-----	--------

**X3S-05B**  
CNC 7075 Chassis Brace (Rear)



1 pc.

	3x10	2 pcs.		3mm	2 pcs.
---	------	--------	---	-----	--------

**X3S-06**  
CNC 7075 Suspension Holder, FF

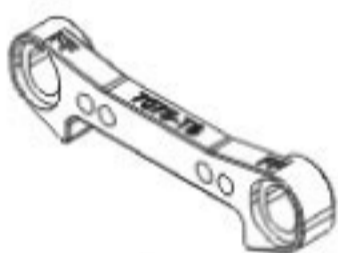

1 pc.

**X3S-07**  
CNC 7075 Suspension Holder, FR



1 pc.

**X3S-08**  
CNC 7075 Suspension Holder, RF

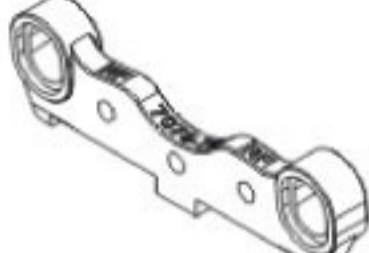

1 pc.

**X3S-09**  
CNC 7075 Suspension Holder, RR

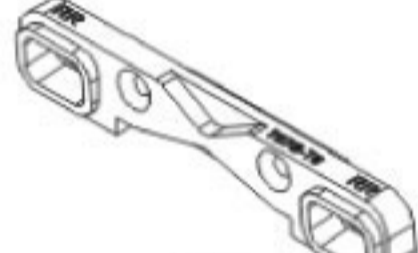

1 pc.

**X3S-10**  
Center CVD Cap Joint



1 pc.

**X3S-11**  
Center CVD Shaft Set, Front, 101.5mm

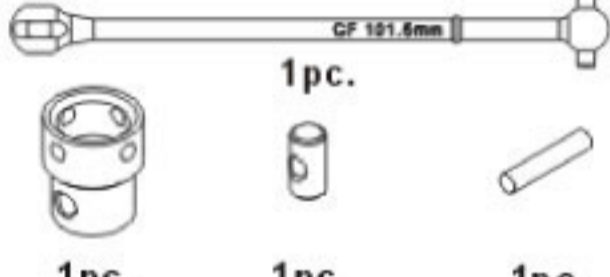

1 pc. 1 pc. 1 pc.

**X3S-11A**  
Center CVD Shaft, Front, 101.5mm



1 pc.

**X3S-12**  
Center CVD Shaft Set, Rear, 113mm

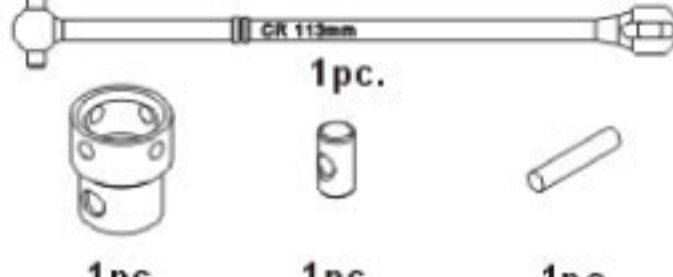

1 pc. 1 pc. 1 pc.

**X3S-12A**  
Center CVD Shaft, Rear, 113mm





1 pc.

**X3S-13**  
Alum. Chassis Brace Mount **OPT**





1 pc.

	4x20	1 pc.		1 pc.
---	------	-------	---	-------

**X3S-14**  
Alum. Rear Hub Carrier L.R. **OPT**



1 pc. 1 pc.

	4mm	4 pcs.		8x16x5	2 pcs.		13x20x4	2 pcs.
---	-----	--------	---	--------	--------	---	---------	--------

**SYMBOLS USED THROUGHOUT THE INSTRUCTION MANUAL**  
說明書附註使用標示

 <b>Parts Bag Used</b> 使用零件包裝袋	 <b>Degrease With Motor Spray</b> 使用清潔噴劑	 <b>Do Not Over Tighten</b> 請勿鎖緊物件	 <b>Tighten</b> 鎖緊物件	 <b>Ensure Free Movement</b> 確定可自由活動	 <b>Contact Adhesive</b> 使用強力打接著劑
 <b>Apply Screw Cement</b> 使用螺絲膠	 <b>Apply Oil</b> 塗上潤滑油	 <b>Apply Lubricant</b> 塗上潤滑黃油	 <b>True-To-Scale</b> 1:1 原寸圖	 <b>Time</b> 時間	 <b>Pay attention here</b> 注意事項



# 1 ASSEMBLY OF THE FRONT AND REAR DIFF. 前後差速齒輪組合

**BAG NO.1**

Build two differentials for front and rear.  
請組合兩個差速器為前後使用。

**Step 1**

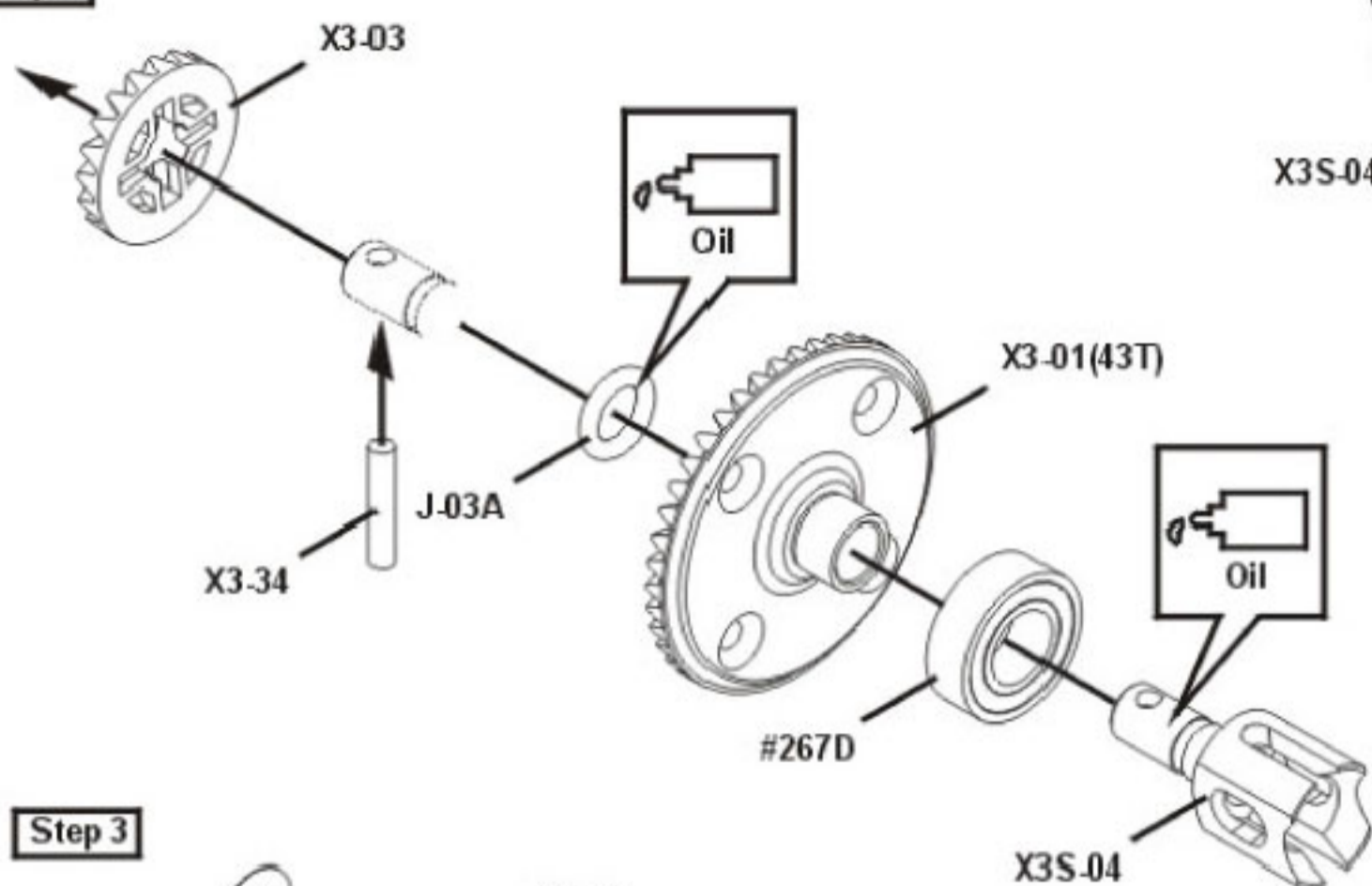

**Step 3**

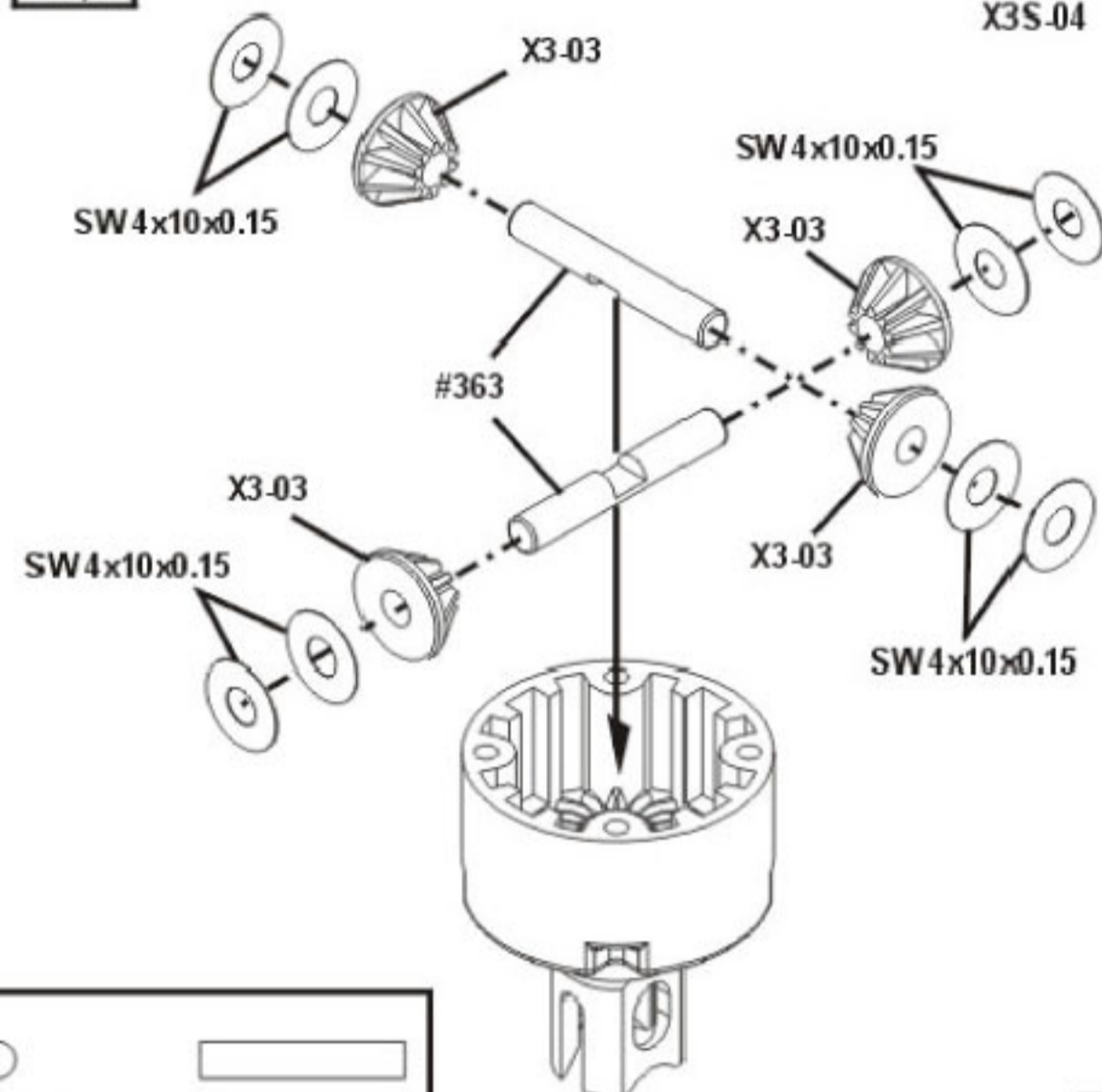

**Step 4**



**Step 5**

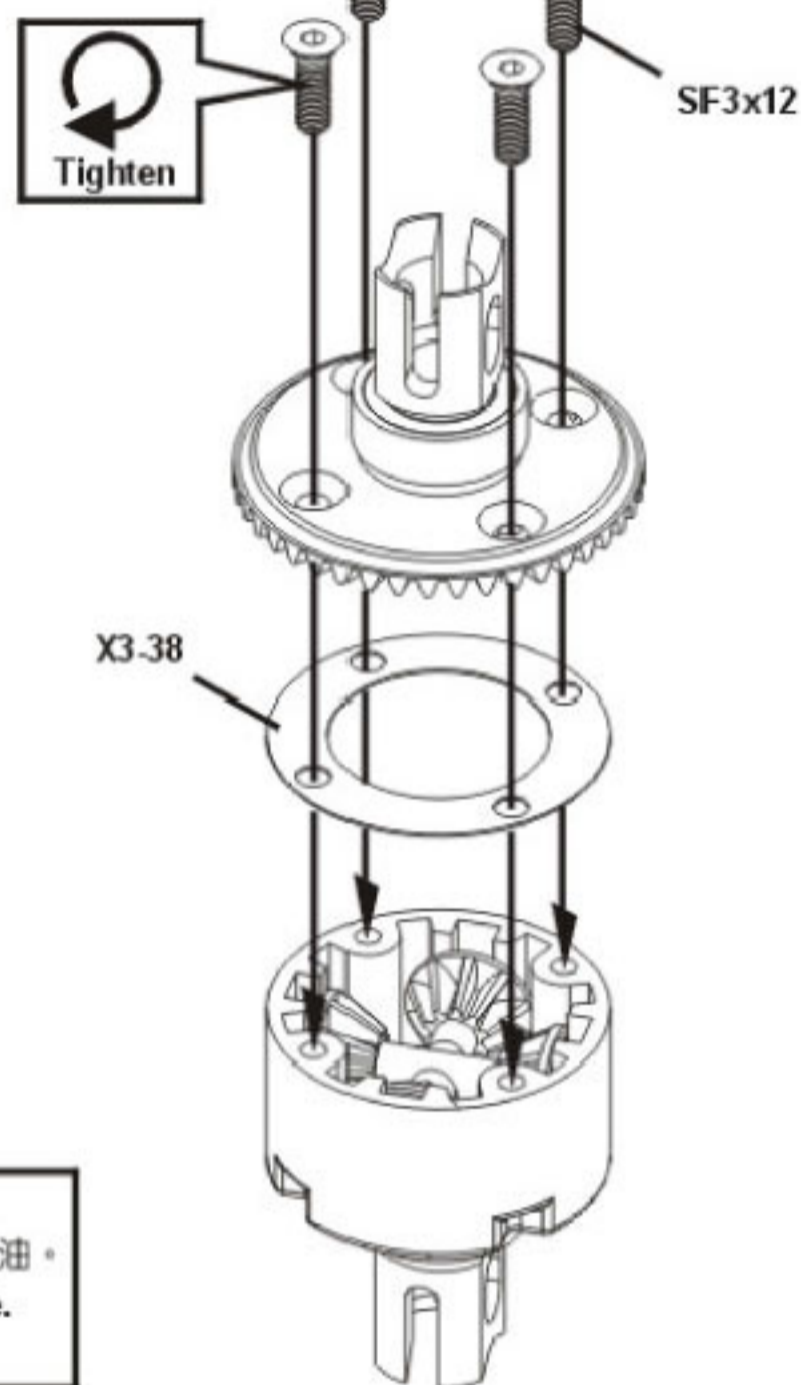

- Use the Diff. Oil #7000 for front and #2000 for rear.  
前差速器請使用 #7000 差速油，後差速器請使用 #2000 差速油。
- Use White Oil pen mark front diff. case and rear diff. case.  
使用白色油漆筆標記前差速殼與後差速殼。

- X3-34  
2.5x11.8mm Pin  
滾針 .....x4
- J-03A  
P6 O-Ring  
P6 O環 .....x4
- #267D  
8x16x5mm  
Ball Bearing  
培林 .....x4
- SW 4x10x0.15  
4x10x0.15mm  
Washer  
墊片 .....x16
- #363  
4mm Alim. Cross Pin  
4mm 鋁十字軸心 .....x4
- SF3x12mm  
Flat Head Hex Screw  
皿頭內六角螺絲 .....x8

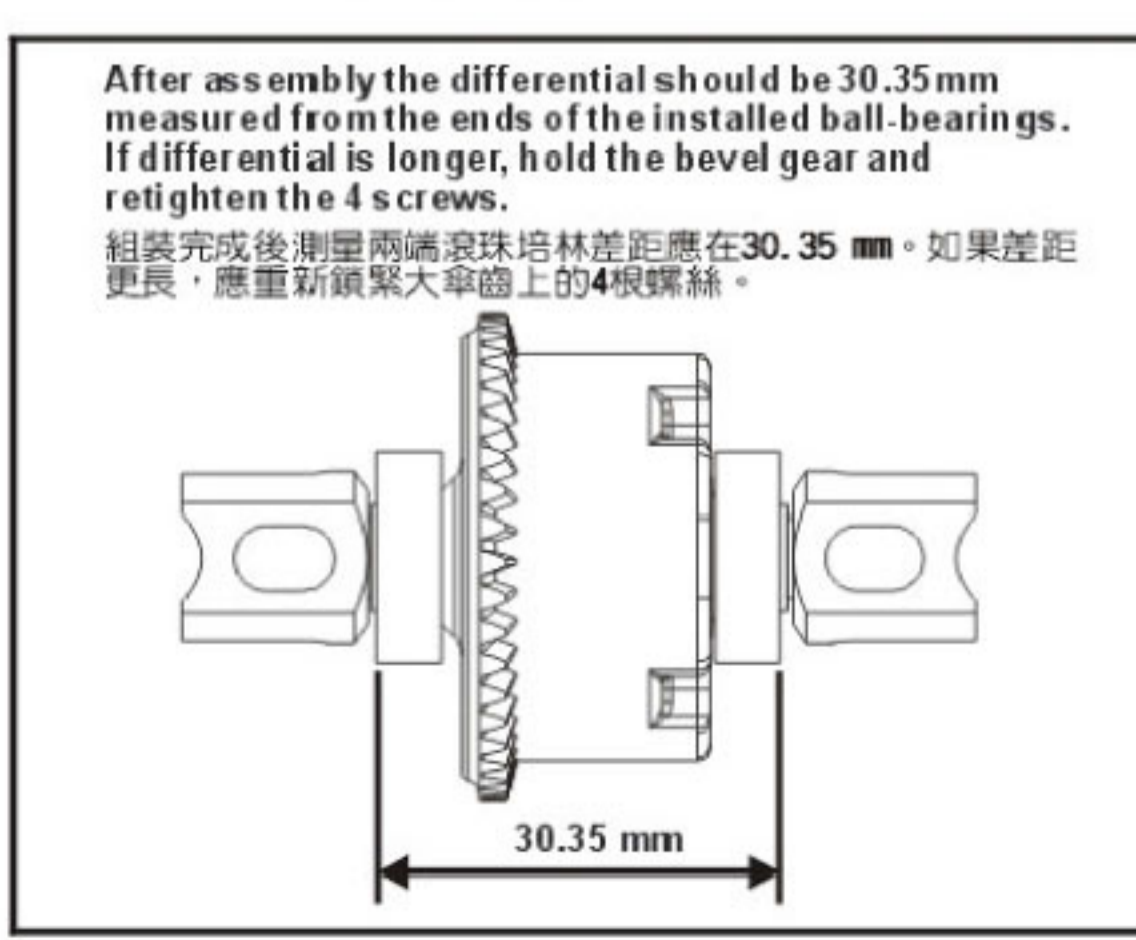
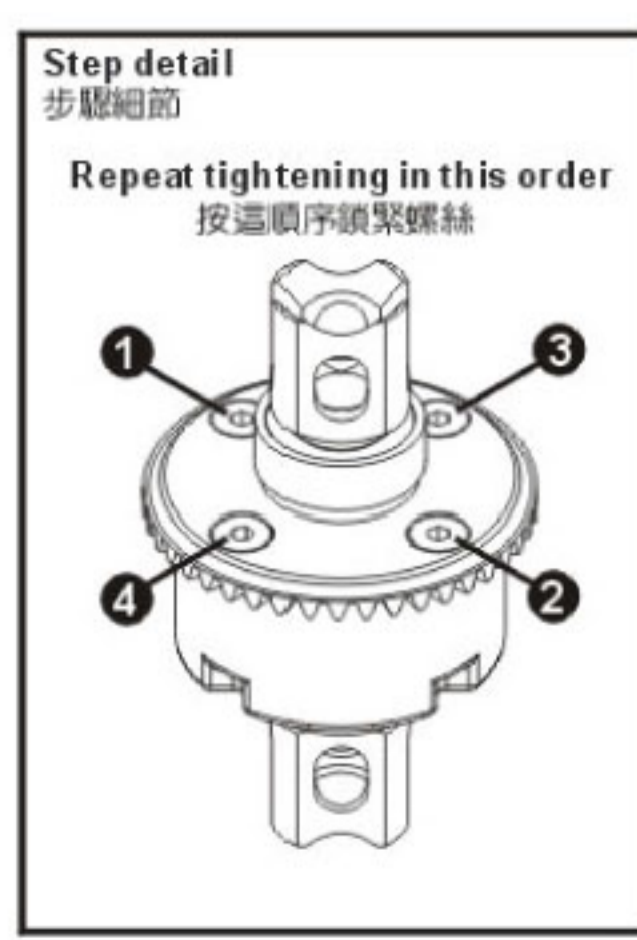
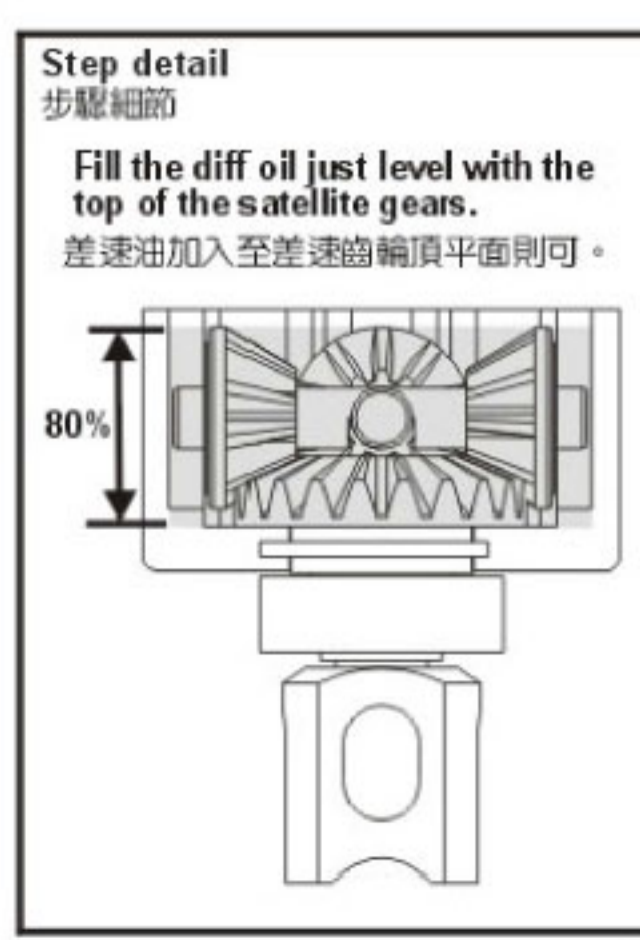
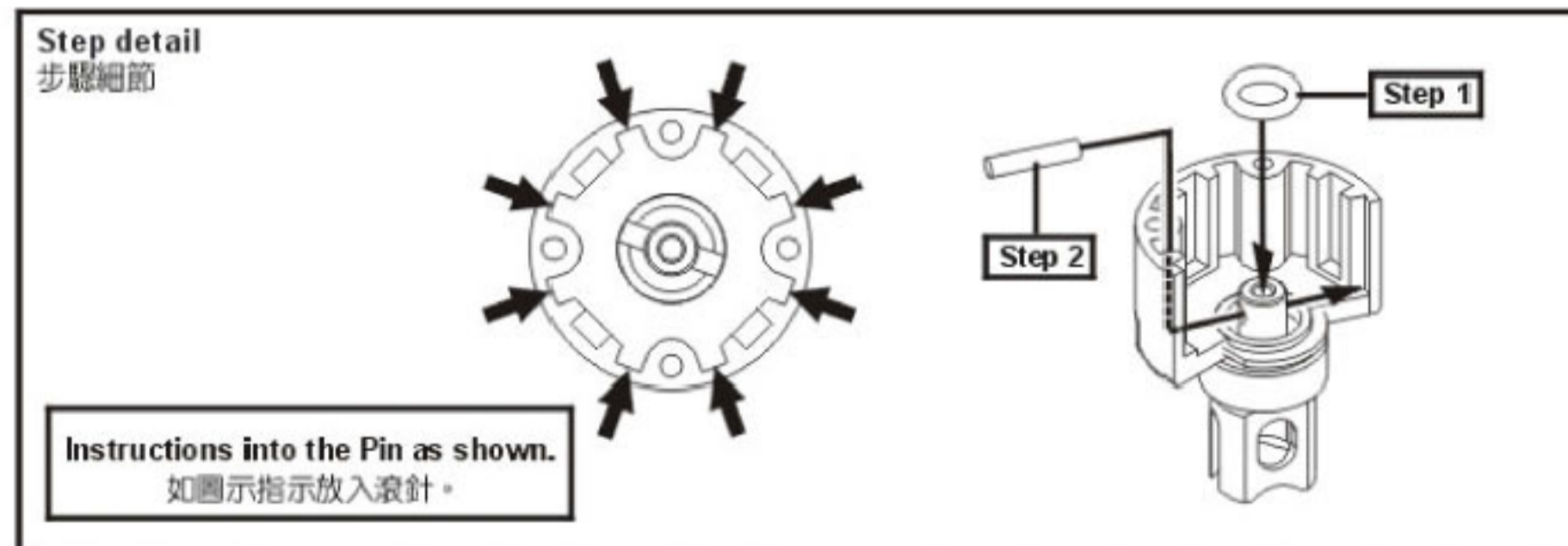
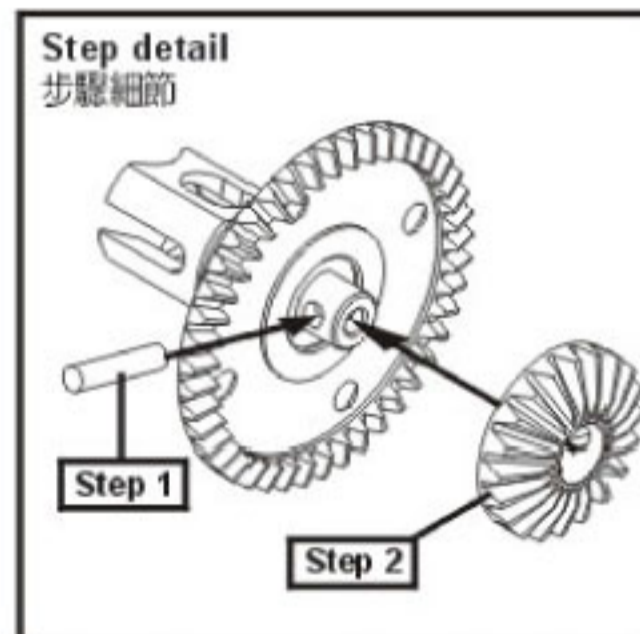



# 2 ASSEMBLY OF THE CENTER DIFF.

中央差速齒輪組合



Step 1

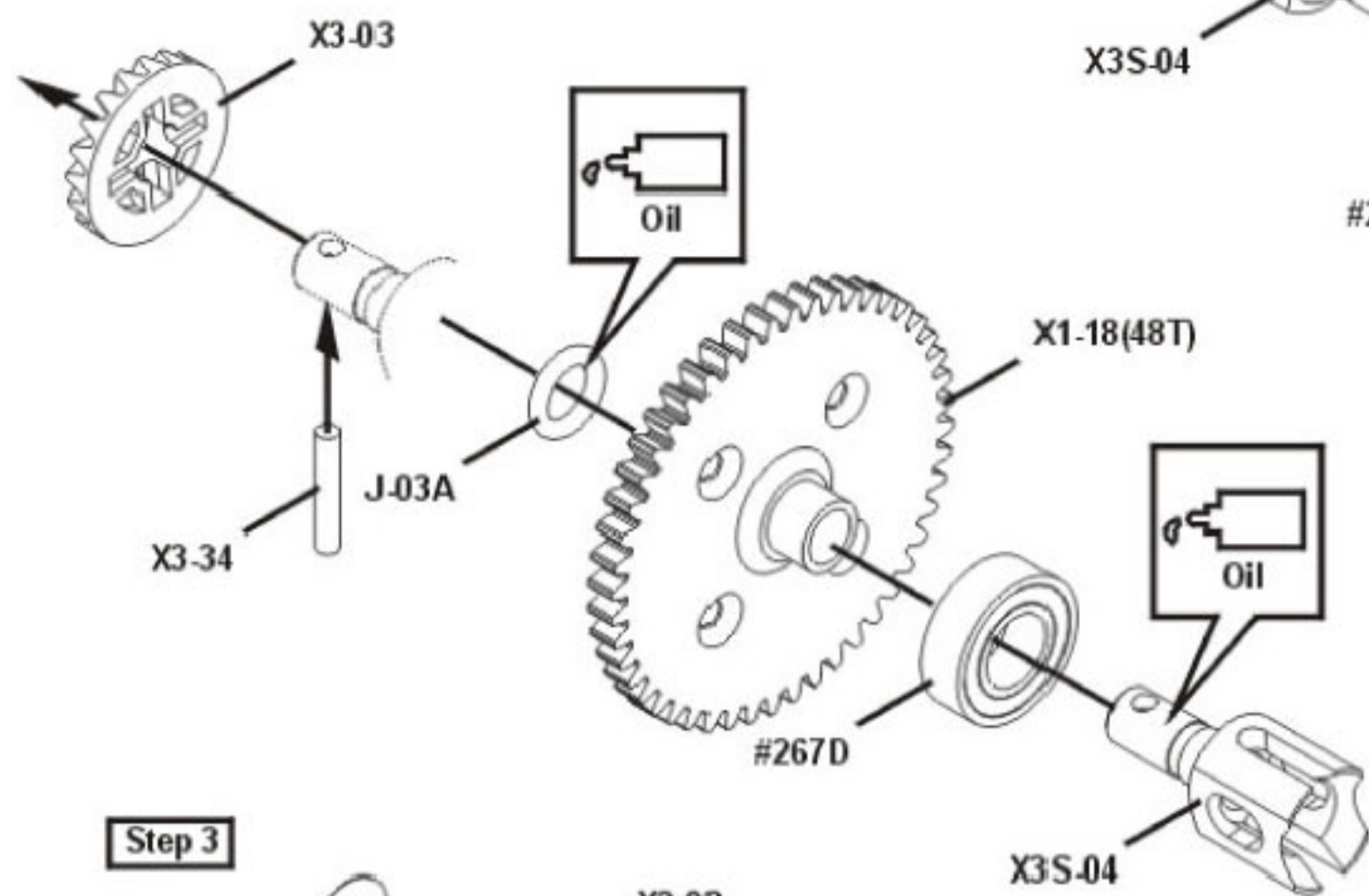

Step 2

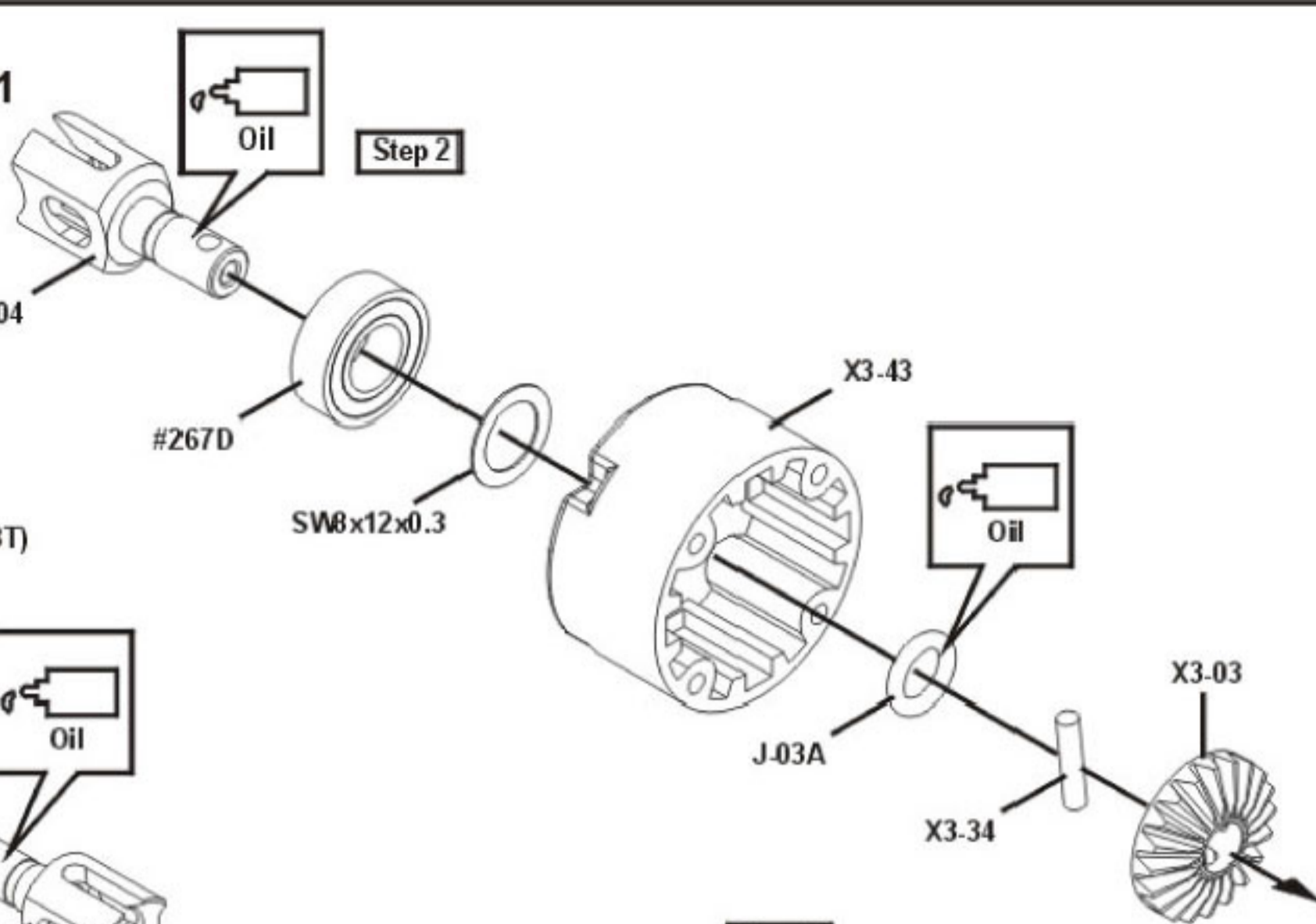

Step 3

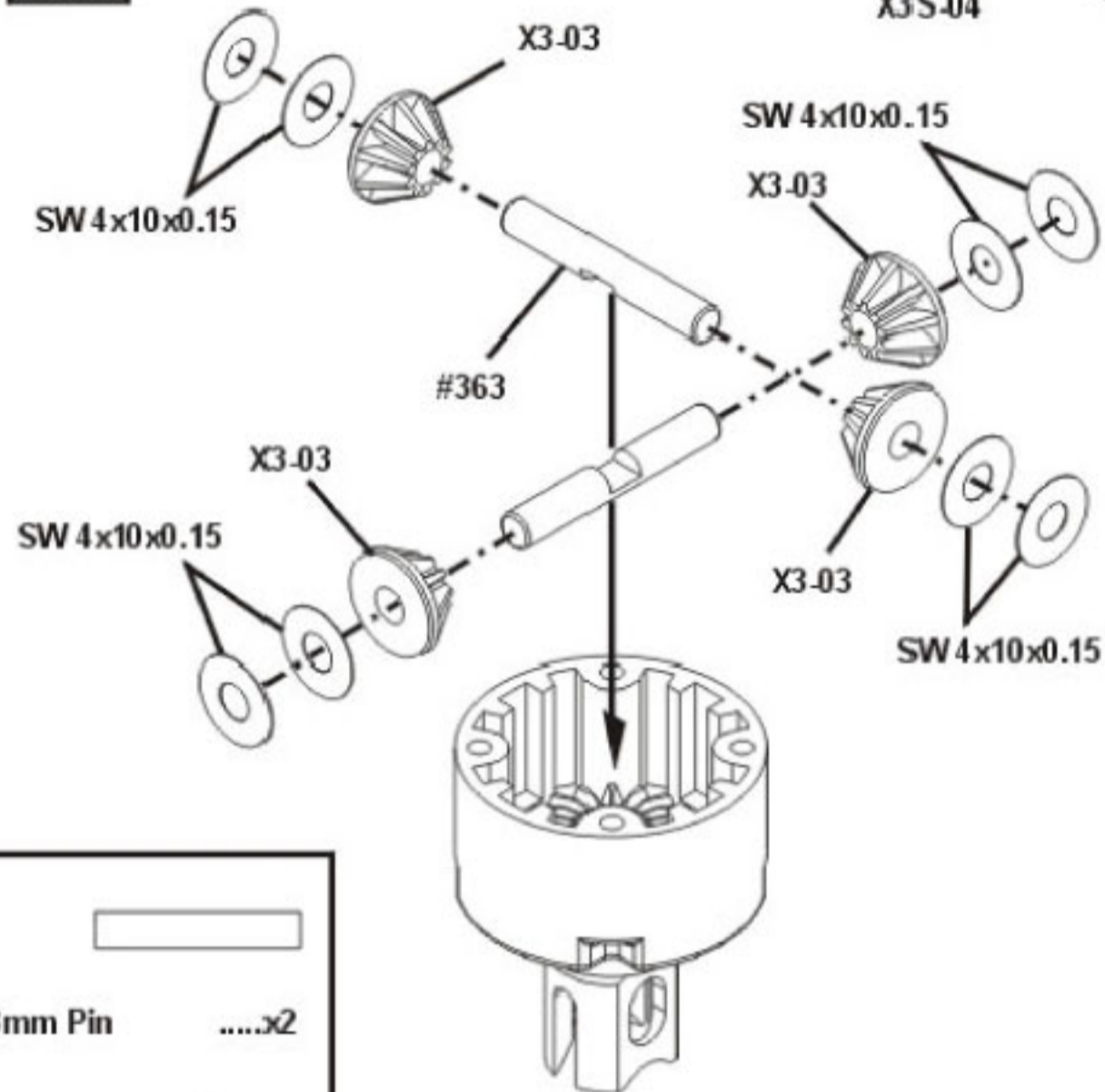

Step 4



Step 5

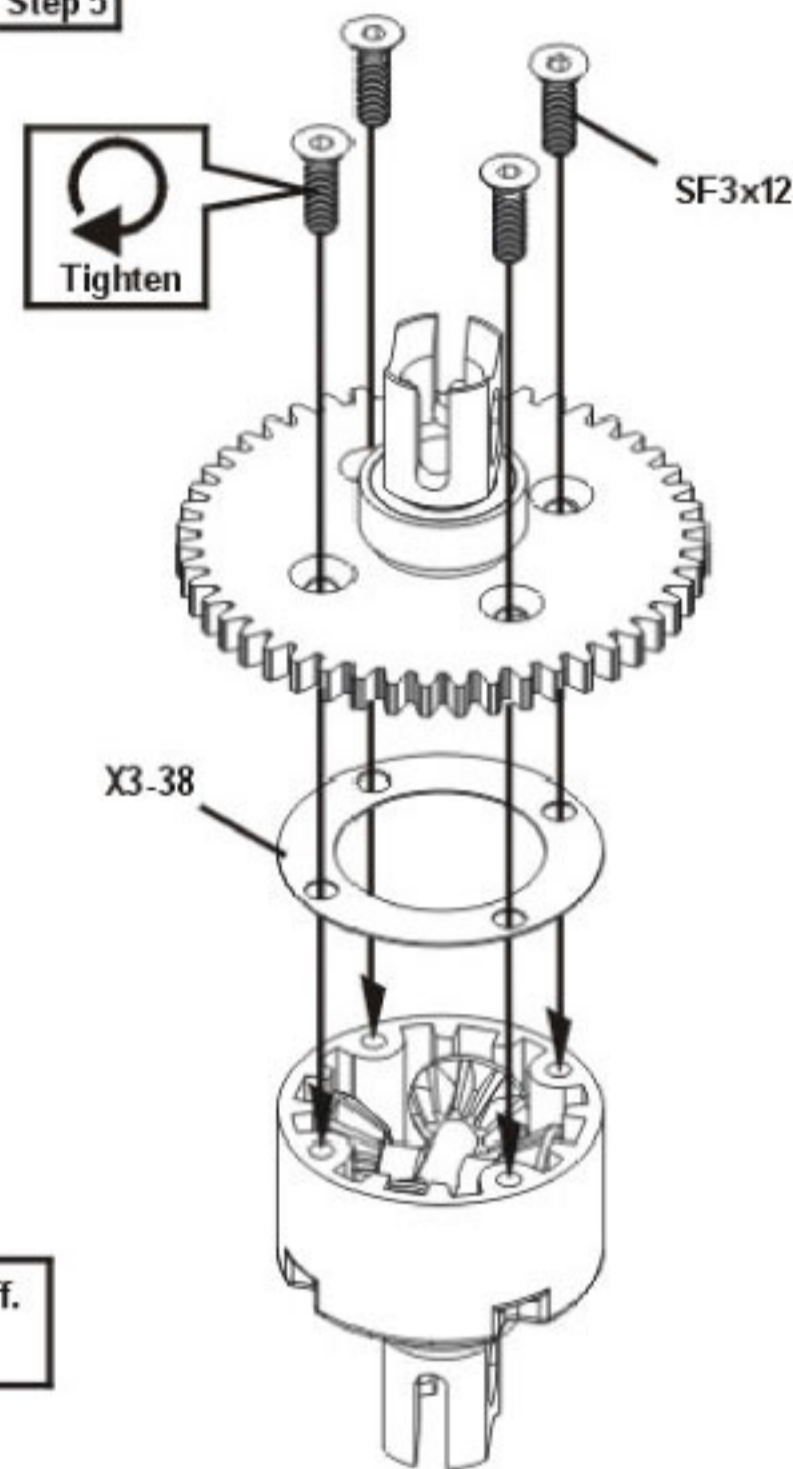

Use the Diff. Oil #5000 for the center diff.  
中差速器請使用 #5000 差速油。

- X3-34  
2.5x11.8mm Pin .....x2  
滾針
- J-03A  
P6 O-Ring .....x2  
P6 O環
- #267D ball bearing"/> #267D  
8x16x5mm Ball Bearing .....x2  
培林
- SW 4x10x0.15  
4x10x0.15mm Washer .....x8  
墊片
- SW8x12x0.3mm  
Washer .....x1  
墊片
- #363 cross pin"/> #363  
4mm Alum. Cross Pin .....x2  
4mm 鋁十字軸心
- SF3x12mm  
Flat Head Hex Screw .....x4  
皿頭內六角螺絲

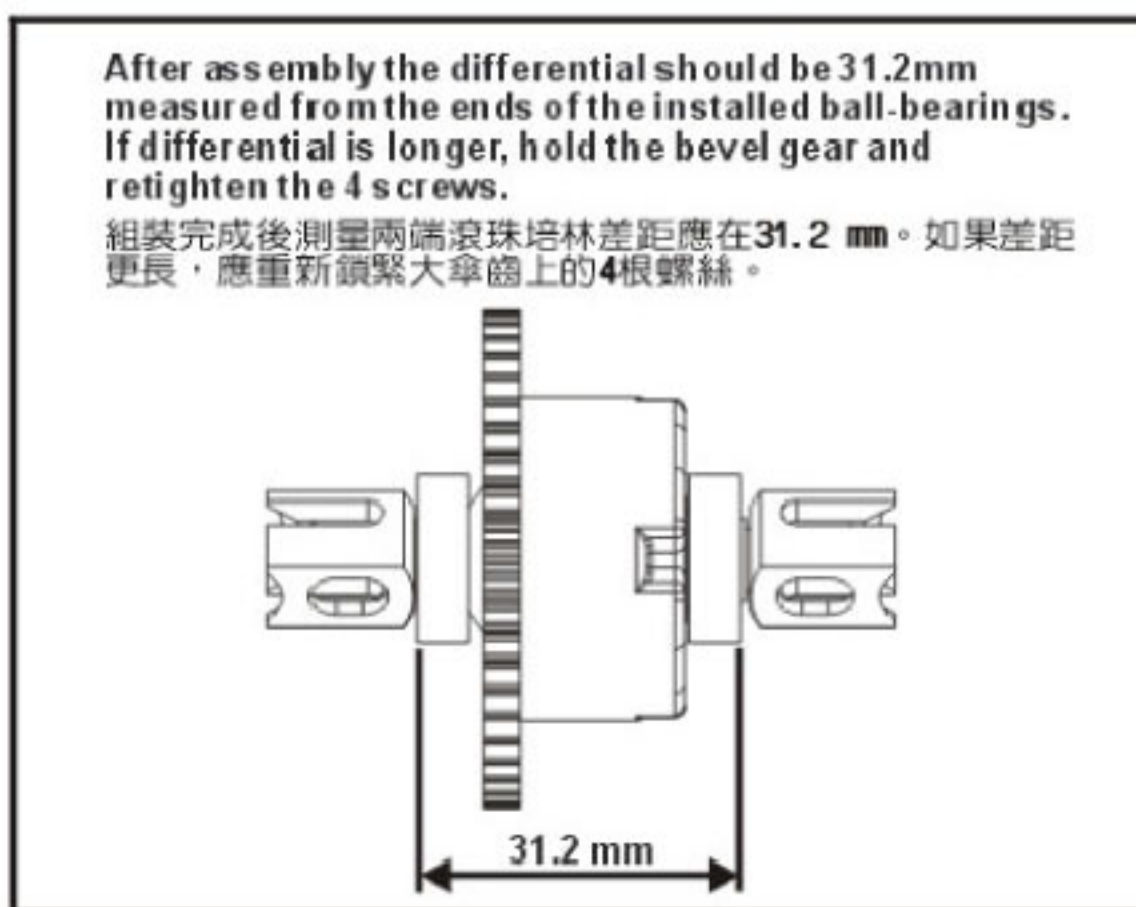
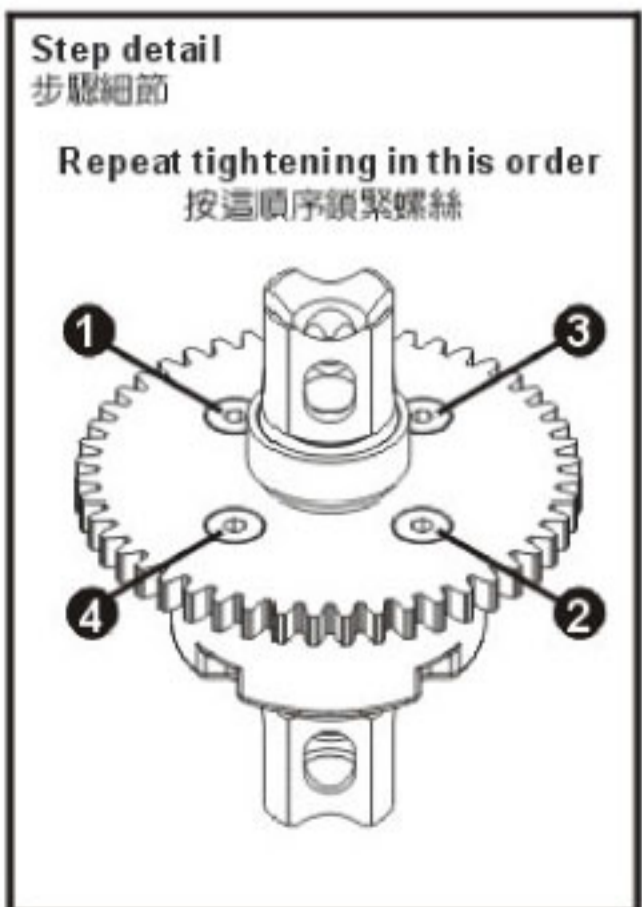
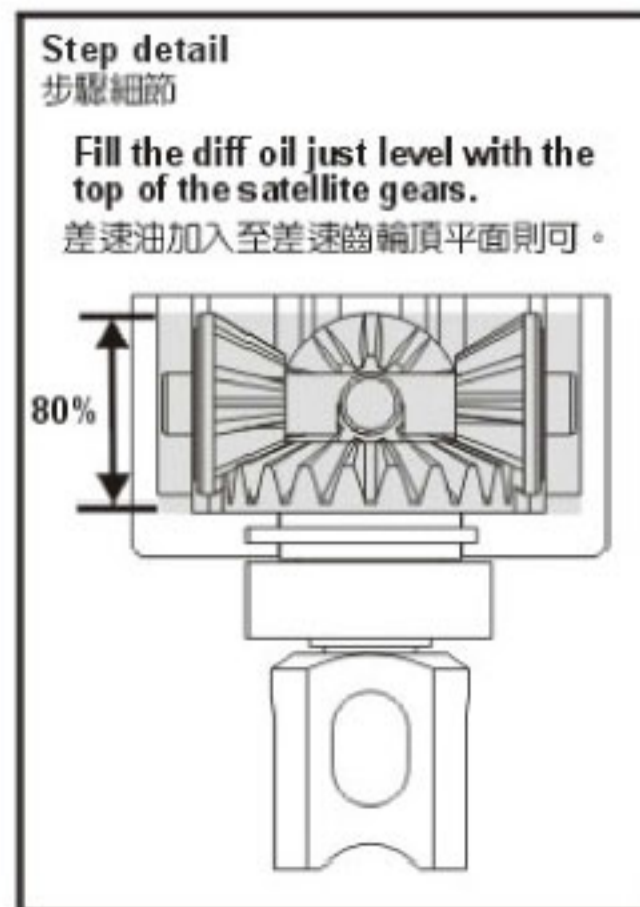
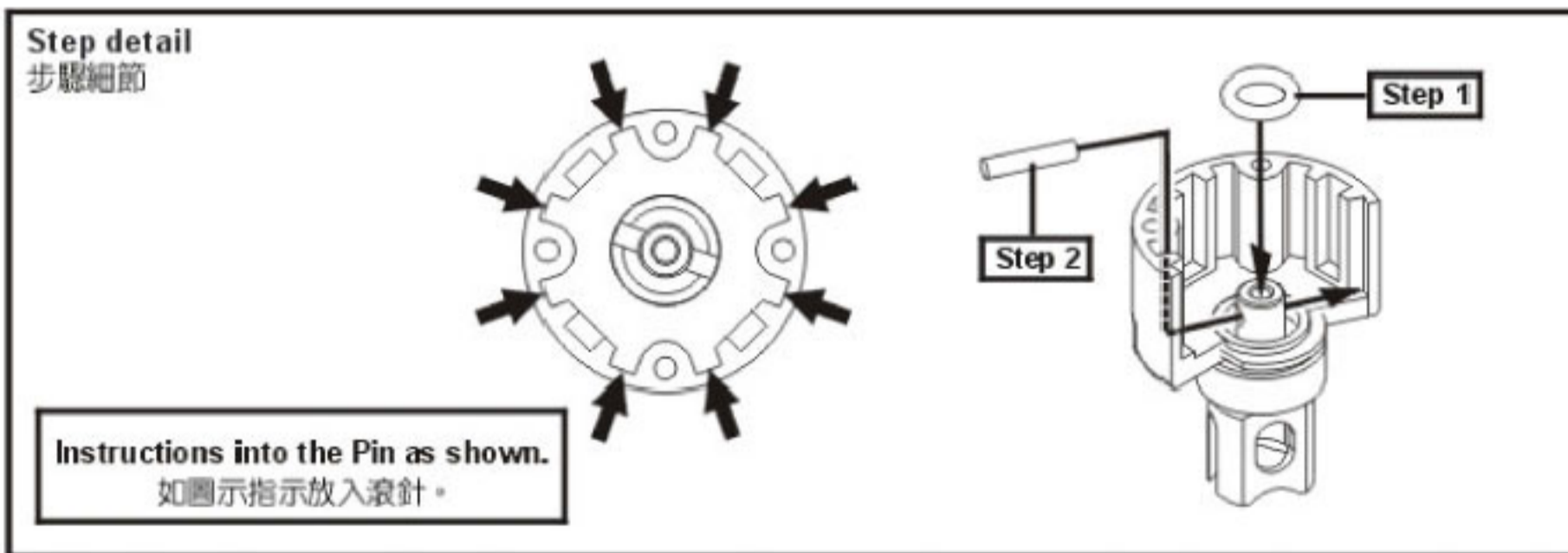
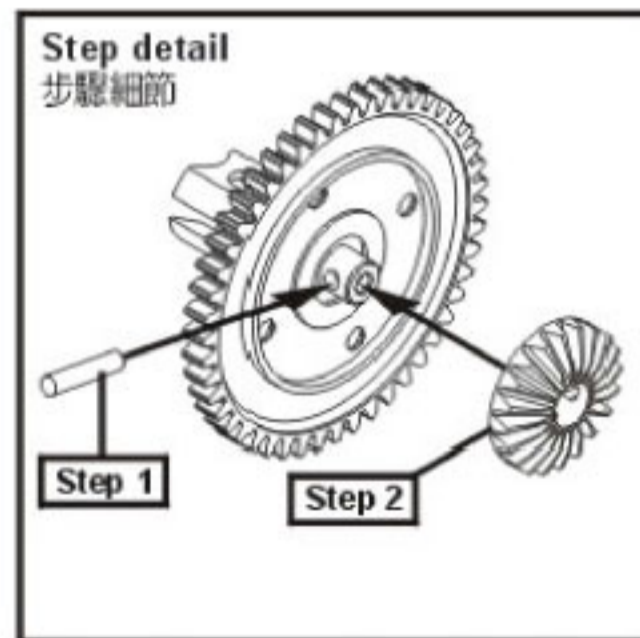
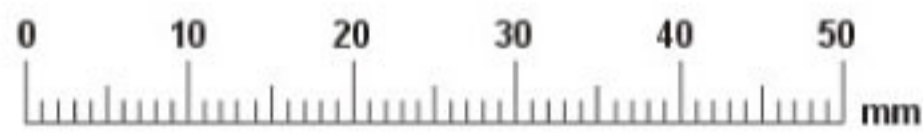



### 3 ASSEMBLY OF THE CENTER/FRONT CVD SHAFT

中央前CVD傳動軸組合

**BAG** NO.2

CF 101.5mm  
For Center/Front  
前中央狗骨 101.5mm

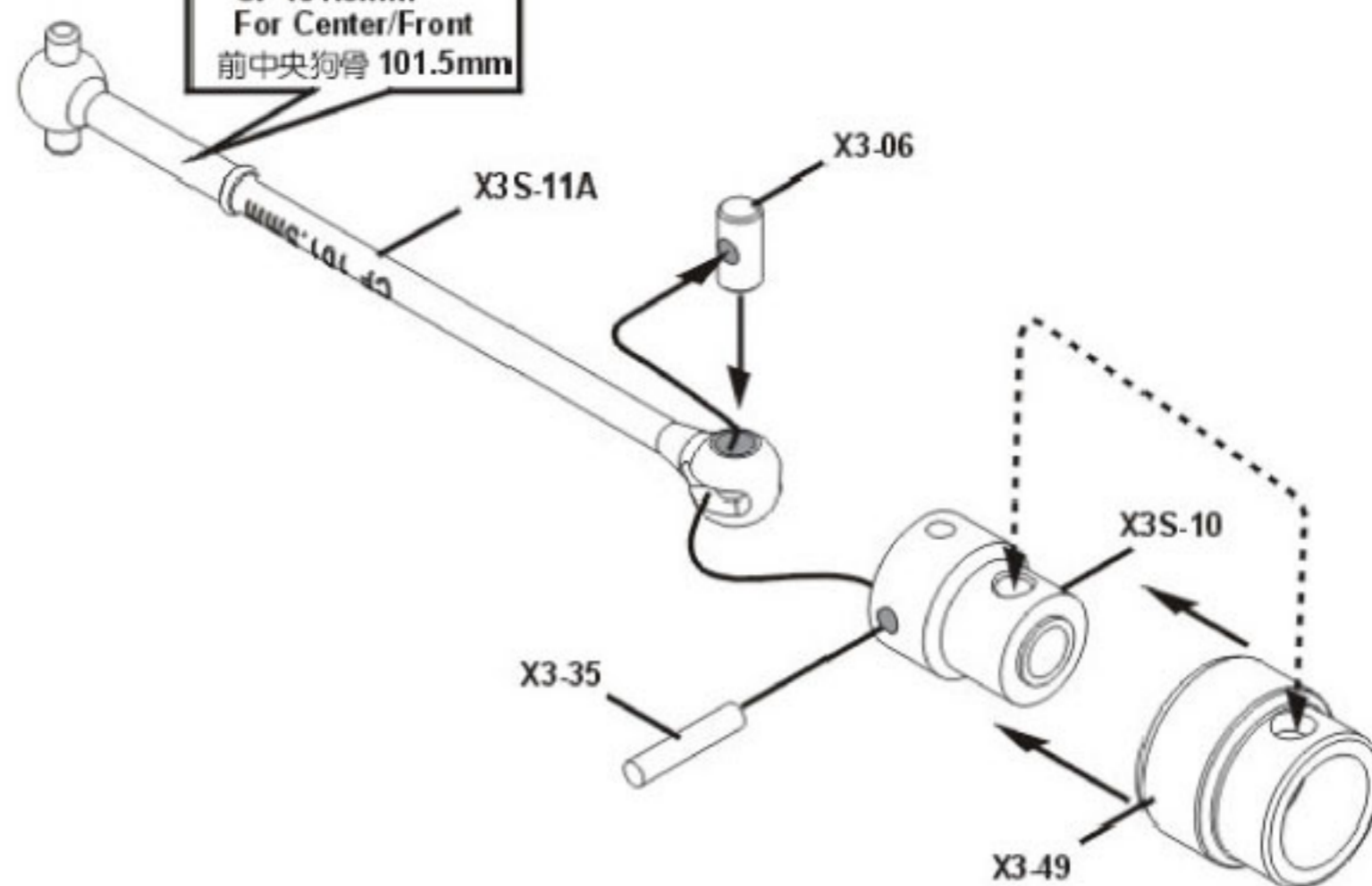

X3-35  
2.5x12.8mm Pin .....x1  
滾針

### 4 ASSEMBLY OF THE FRONT GEAR CASE

前齒輪箱組合

**BAG** NO.2

SW2.6x6x0.5mm  
Washer  
墊片 .....x1

E-43  
5x11x4mm  
Ball Bering  
培林 .....x2

SB2.5x5mm  
Hex Screw  
丸頭內六角螺絲 .....x1

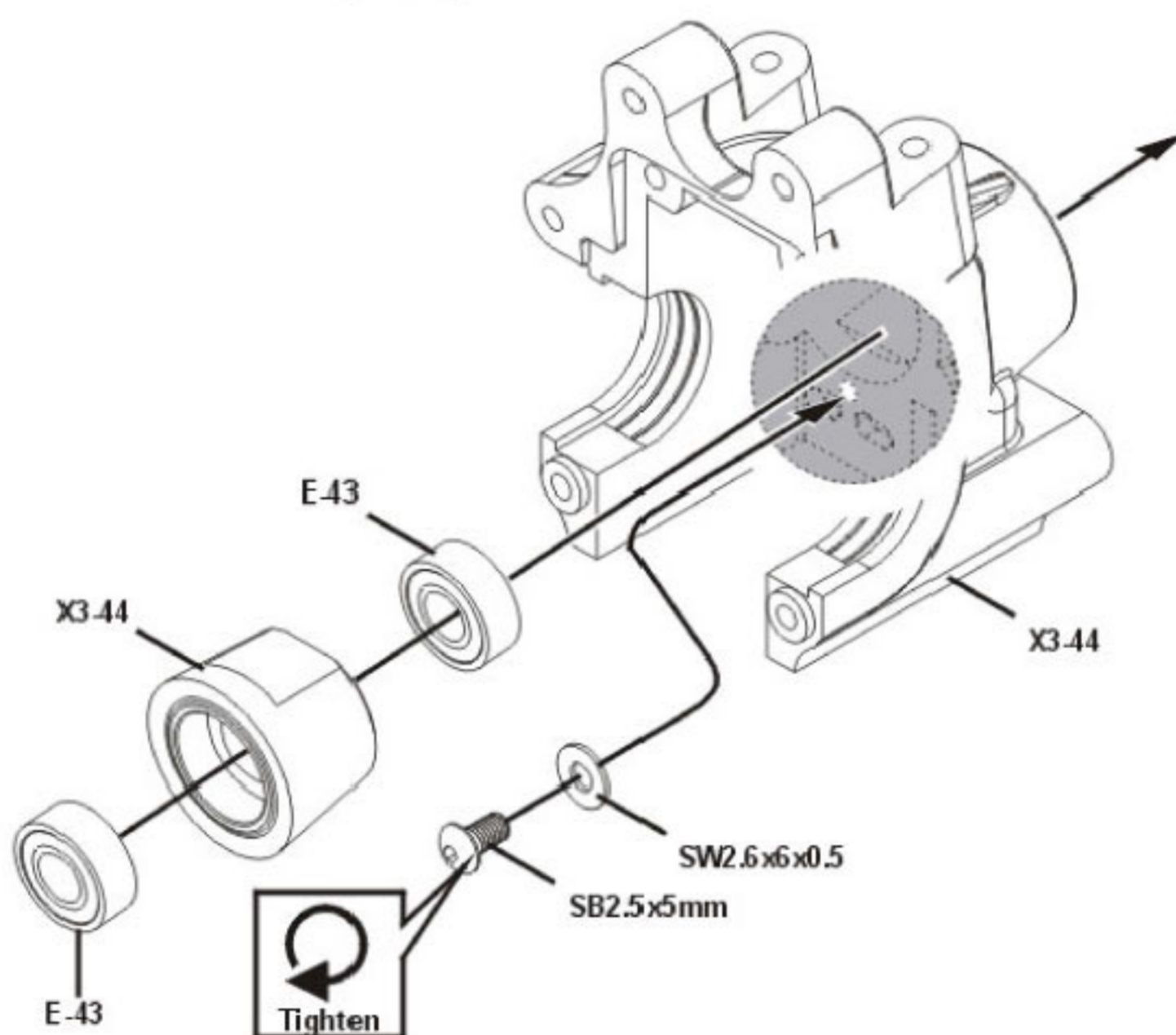

Step detail  
步驟細節

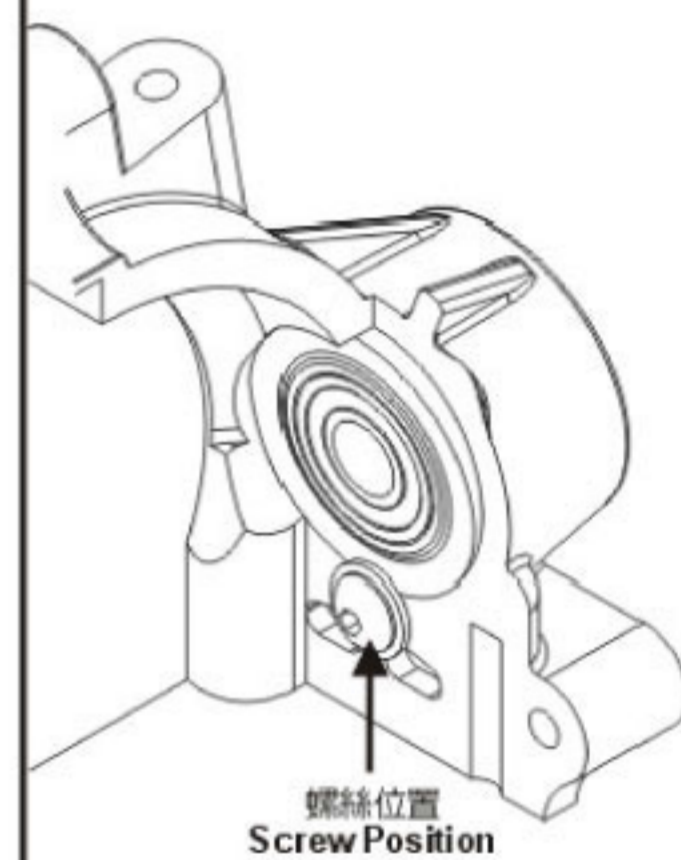

螺絲位置  
Screw Position

### 5 ASSEMBLY OF THE FRONT PINION GEAR AND CVD SHAFT

前小傘齒與CVD傳動軸組合

**BAG** NO.2

SW6x8x0.3mm  
Washer  
墊片 .....x1

SS4x6mm  
Set Screw  
止付螺絲 .....x1

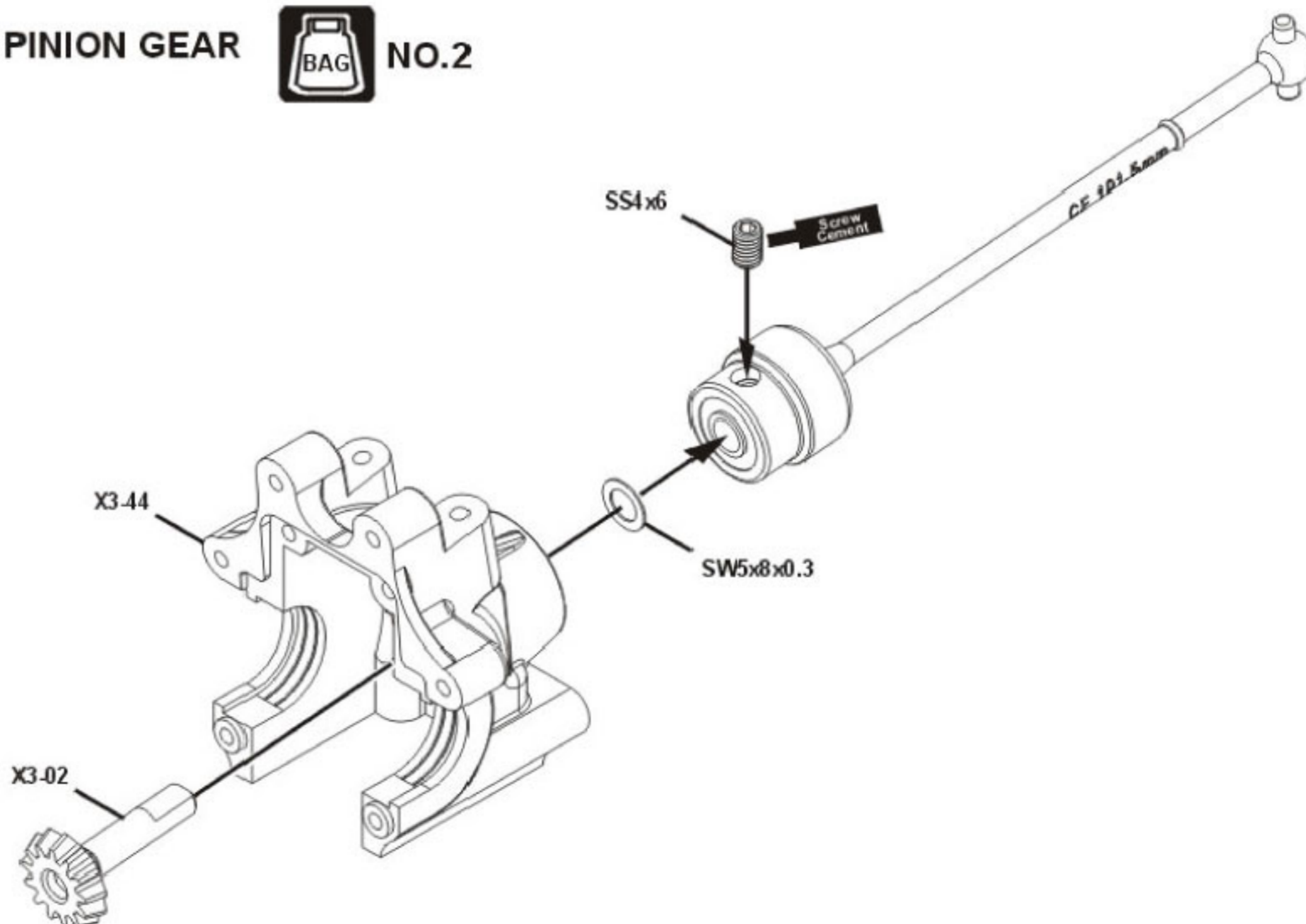



## 6 ASSEMBLY OF THE FRONT DIFFERENTIAL INTO GEAR CASE

前差速器與齒輪箱組合



Adjust the backlash with the Shims.  
請使用墊片調整間隙。

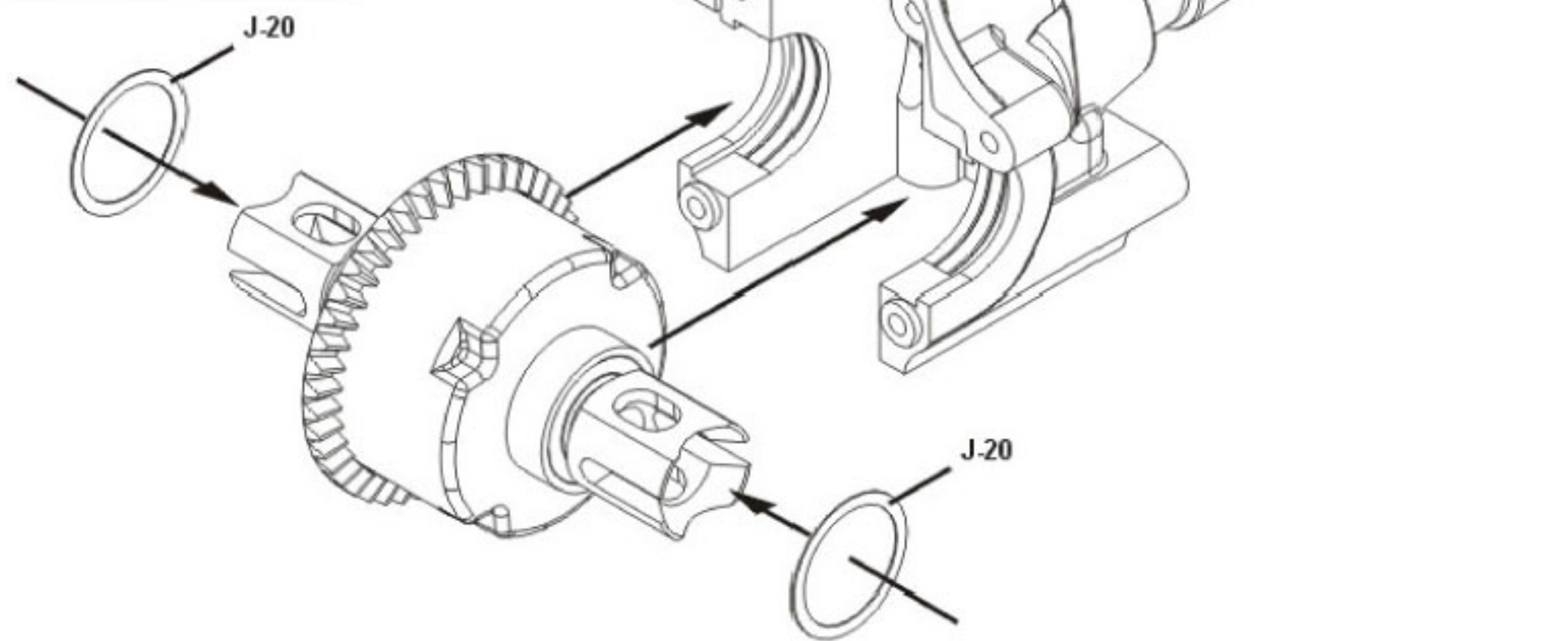

J-20  
13x16 x0.2mm  
Shim  
墊片 .....x2

## 7 ASSEMBLY OF THE FRONT GEAR CASE COVER

前齒輪箱蓋組合



SF3x15mm  
Flat Head Hex Screw .....x2  
皿頭內六角螺絲

SB3x35mm  
Hex Screw .....x2  
半丸內六角螺絲

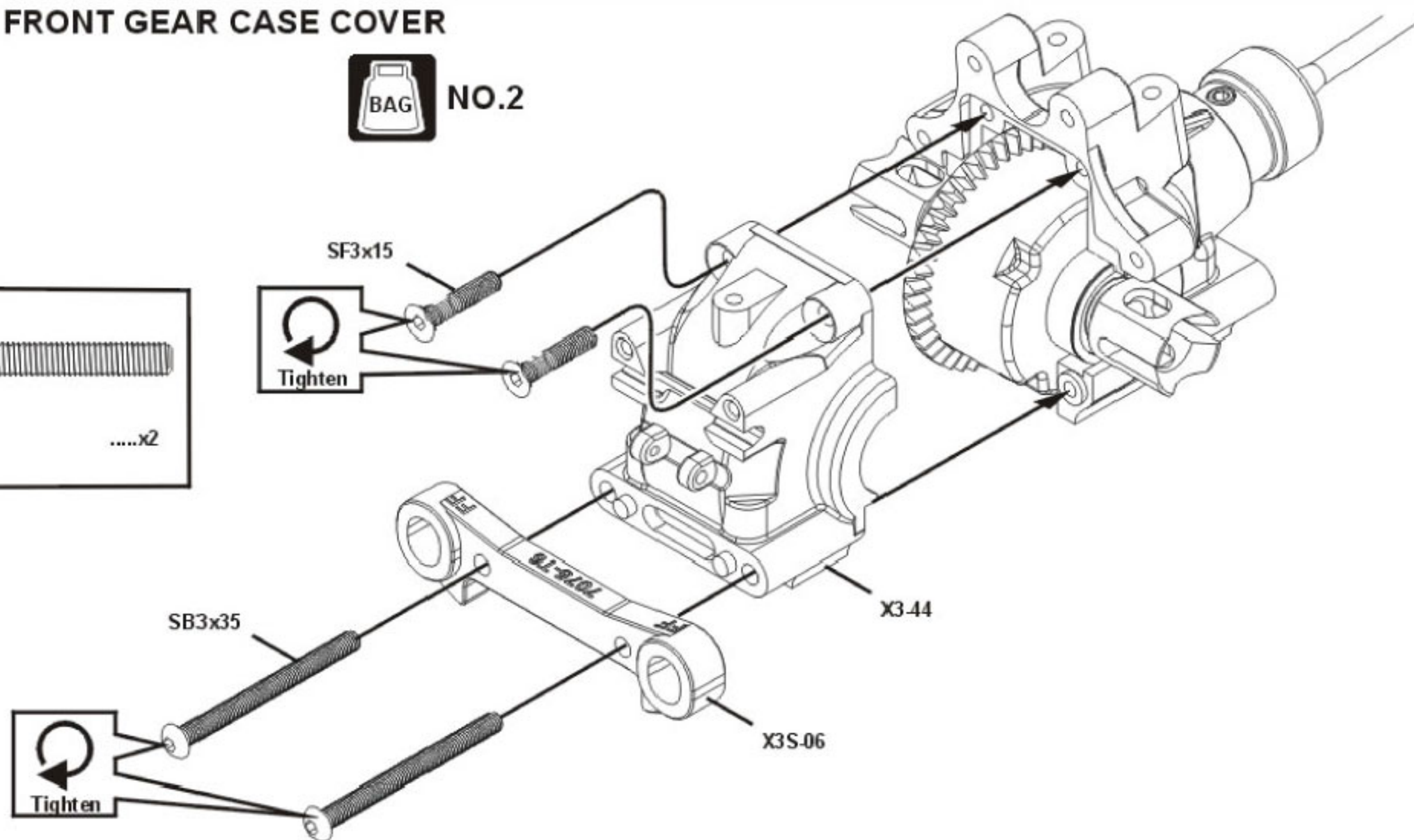

## 8 ASSEMBLY OF THE FRONT SHOCK STAY

前油壓架組合

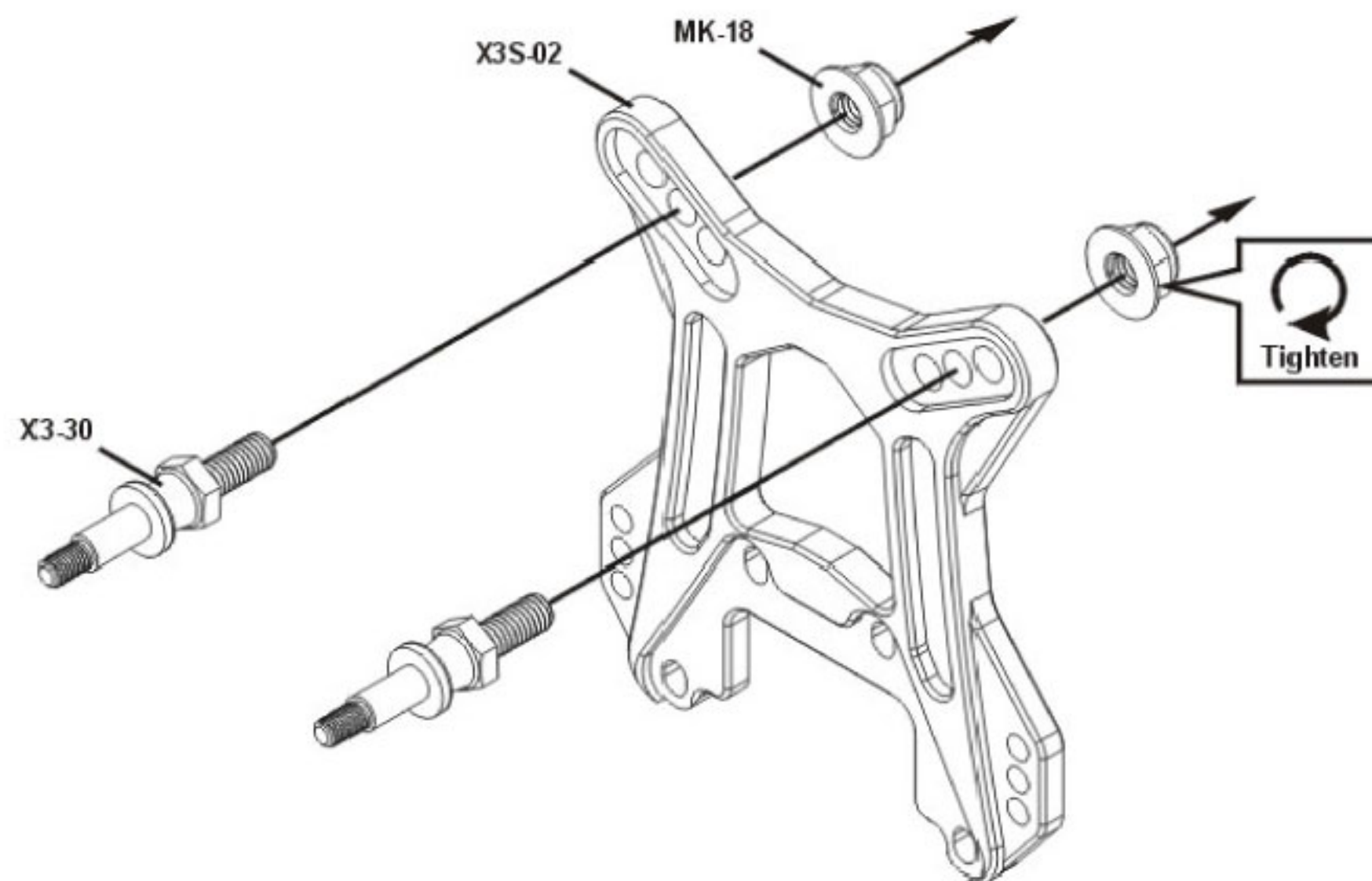

MK-18  
4mm  
Nylon Nut  
尼龍螺帽 .....x2



## 9 ASSEMBLY OF THE FRONT SHOCK STAY ONTO GEAR CASE

前油壓架與齒輪箱組合

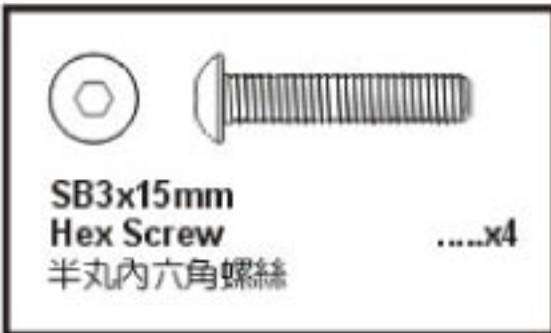
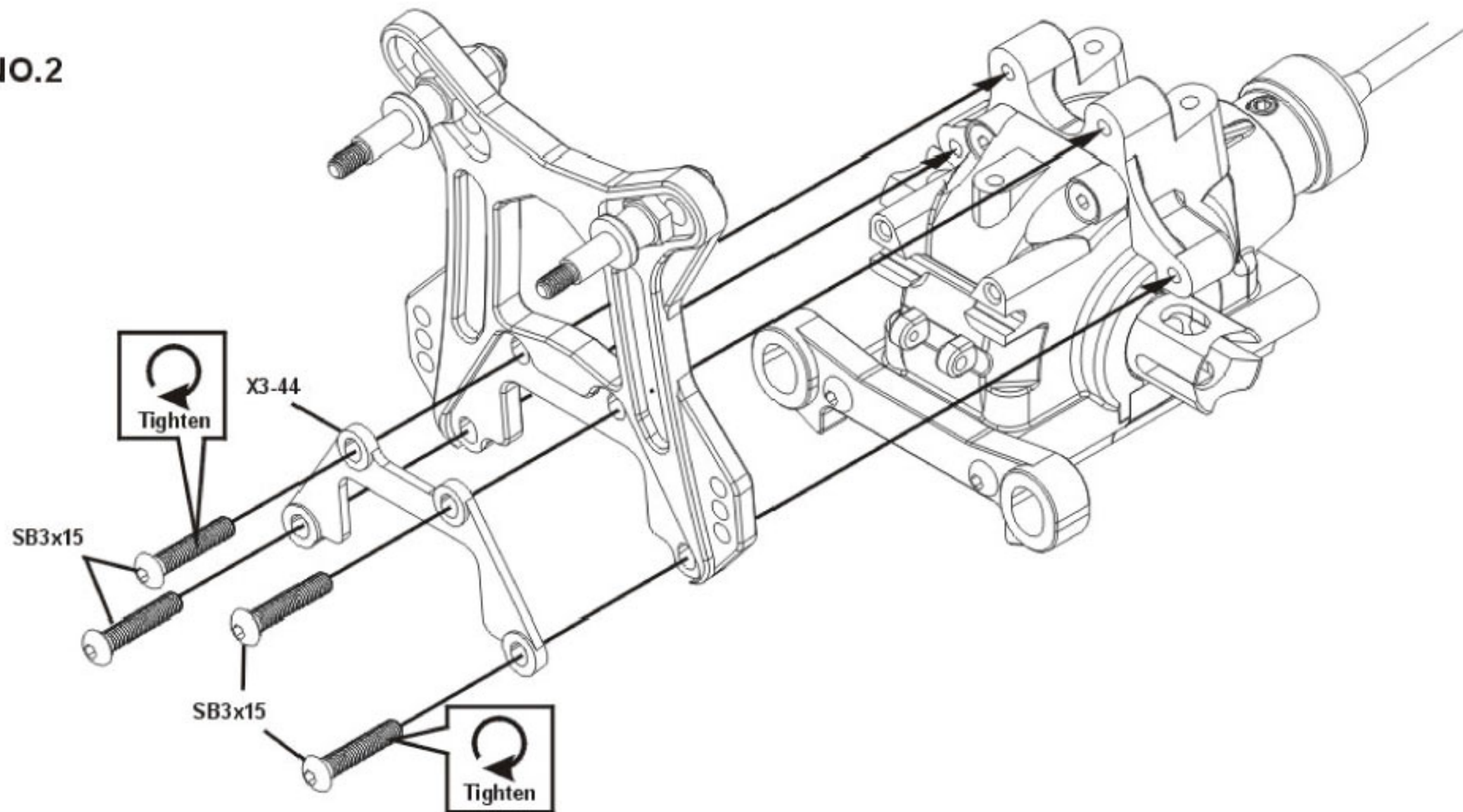

## 10 ASSEMBLY OF THE FRONT LOWER ARMS

前齒輪箱組合



Assemble both right and left sides.  
請組合左右兩側。

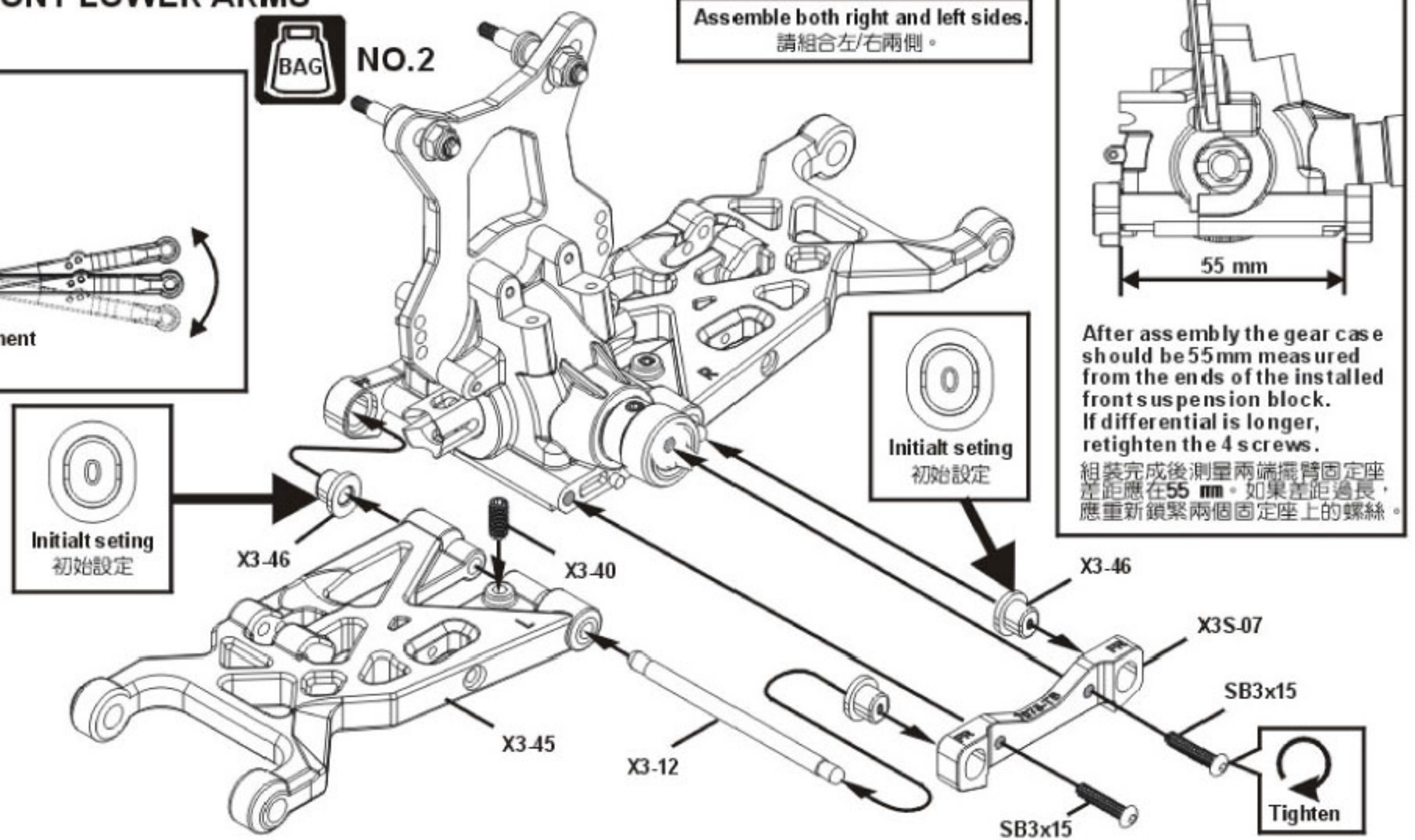
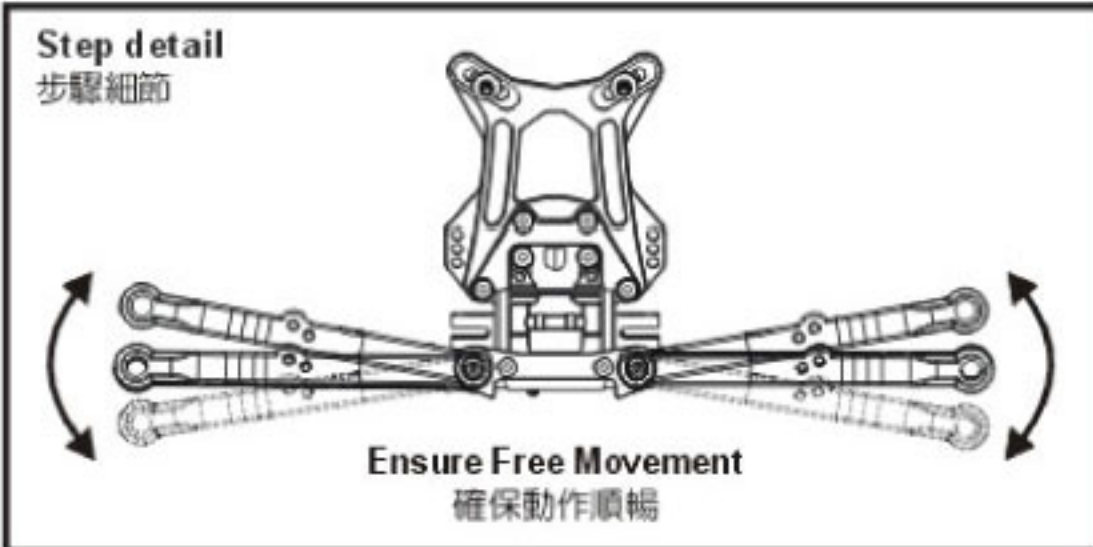

## 11 ASSEMBLY OF THE FRONT STABILIZER ROD

前平衡桿組合

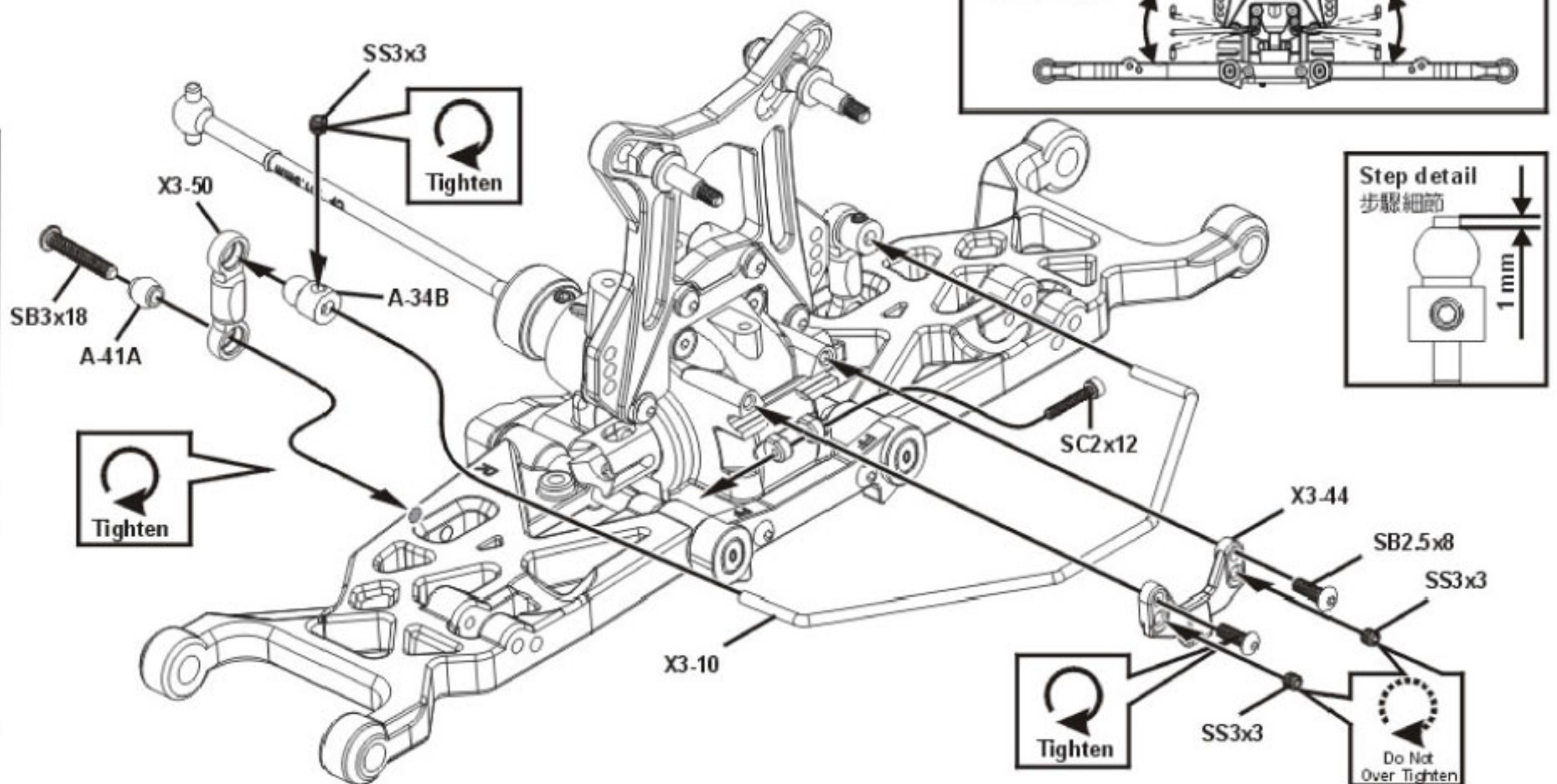
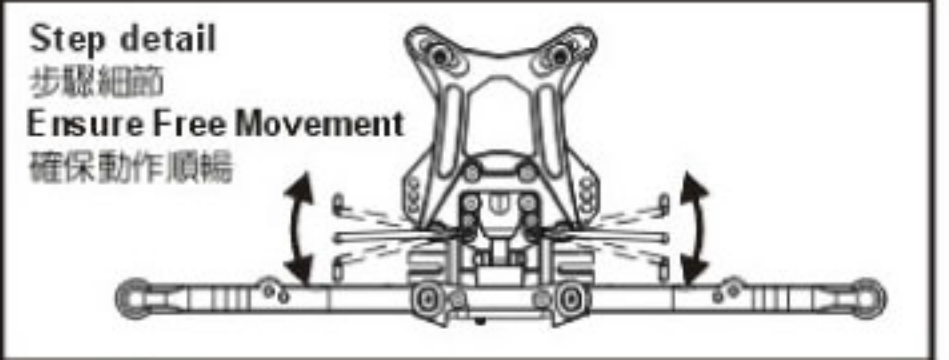



## 12 ASSEMBLY OF THE FRONT KNUCKLE ARMS

轉向座組合

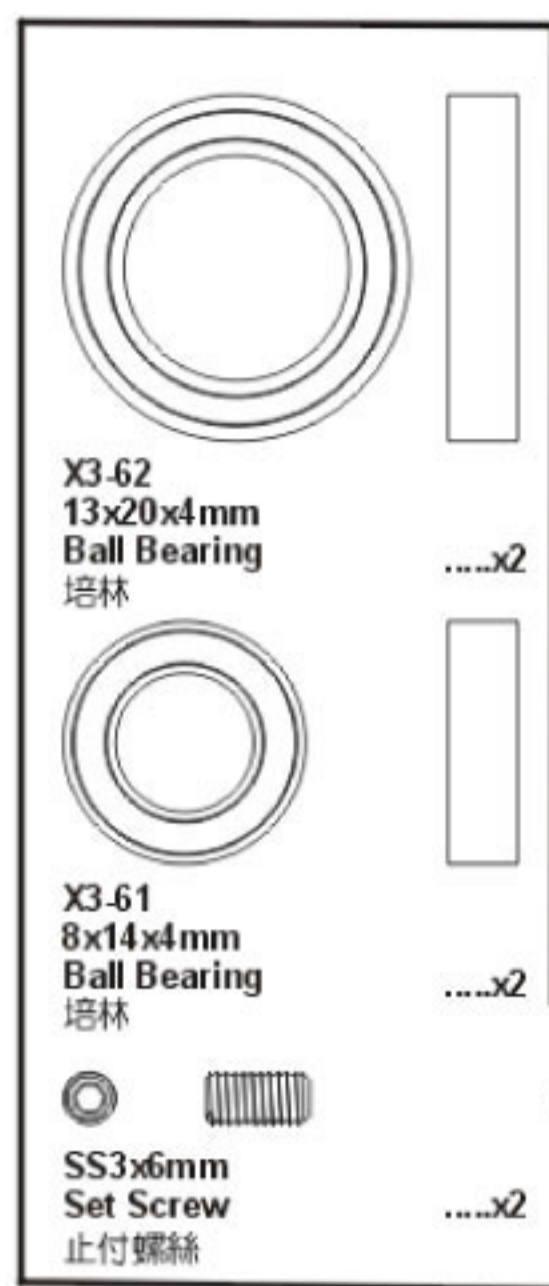

LEFT SIDE  
左側

**BAG** NO.2

Step 1

Step 2

Step 3

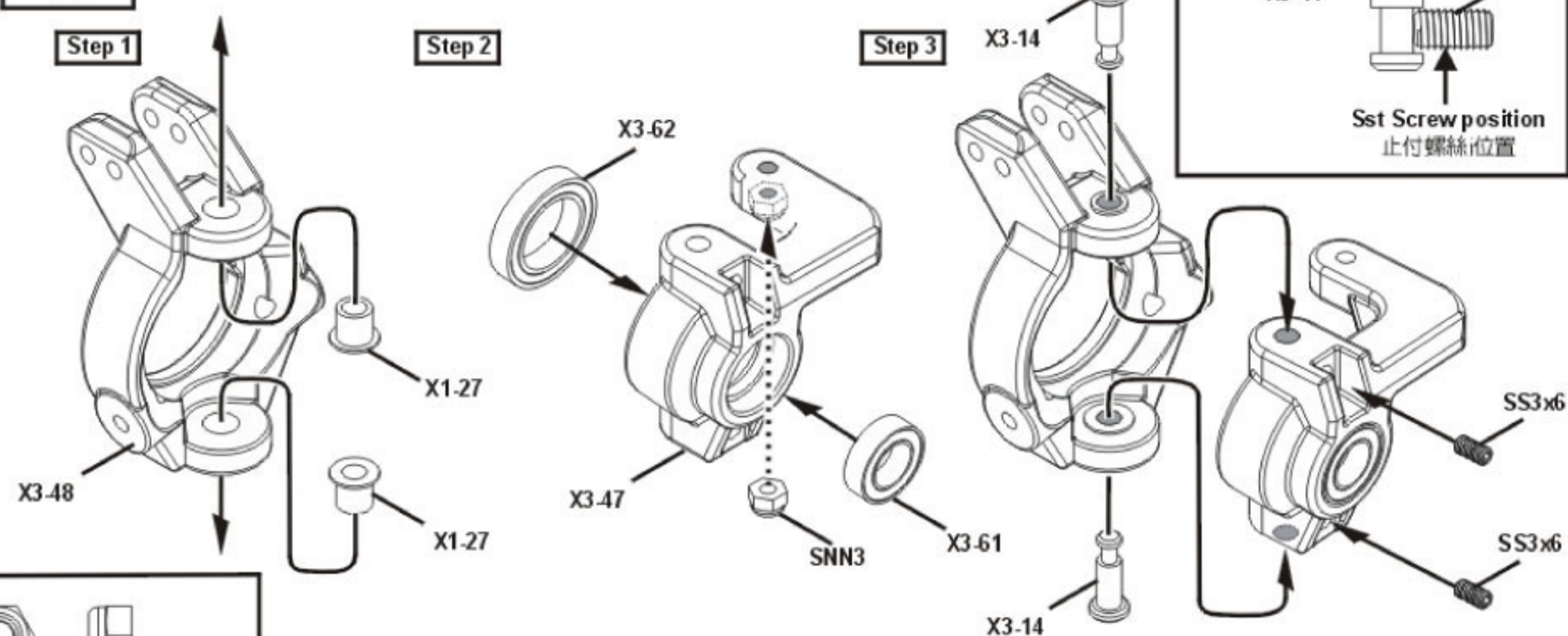

Assemble both right and left sides  
請組合左/右兩側。

## 13 ASSEMBLY OF THE FRONT CVD INTO KNUCKLE ARMS

轉向座與CVD傳動軸組合

**BAG** NO.2

LEFT SIDE  
左側

Assemble both right and left side.  
請組合左/右兩側。

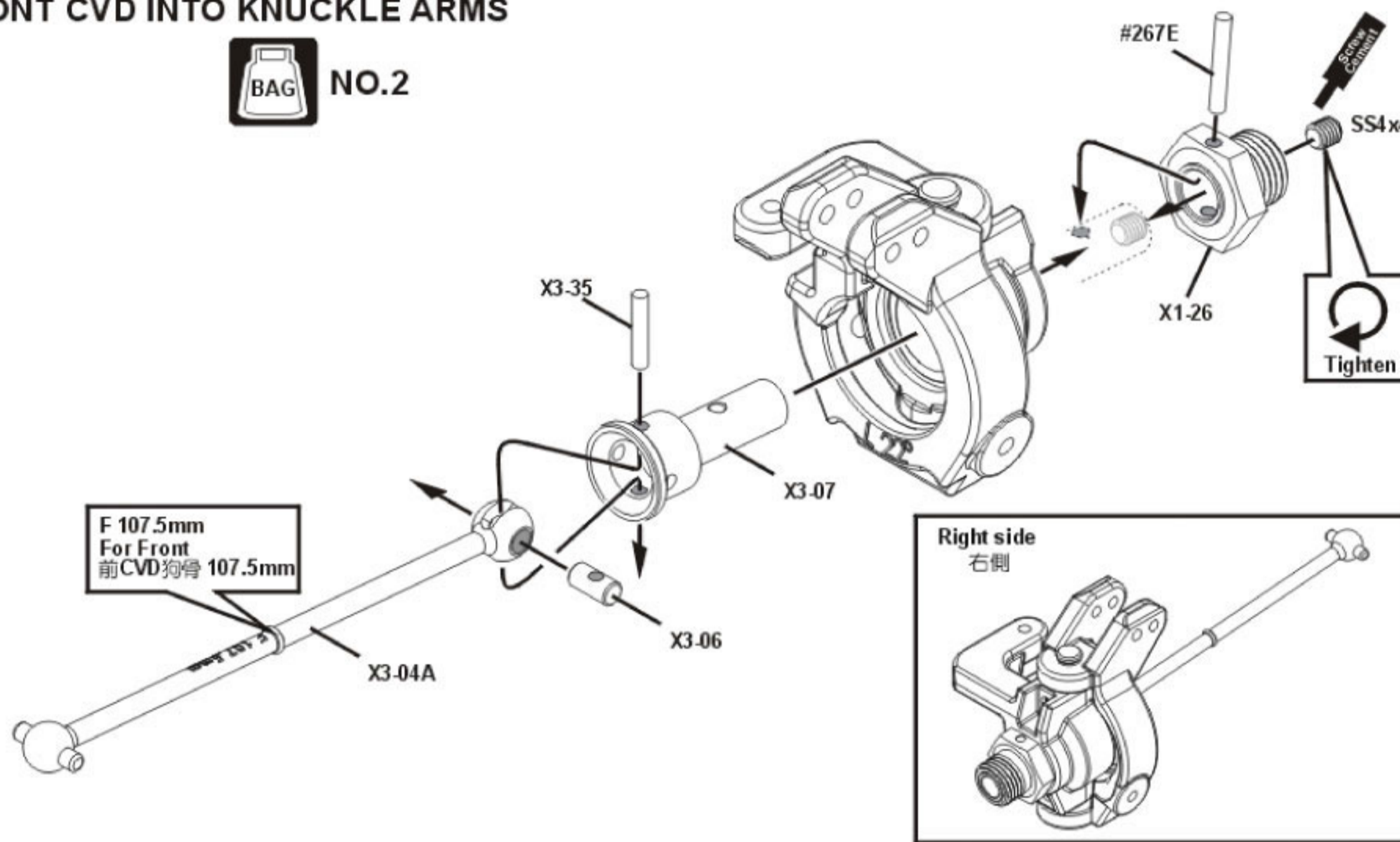
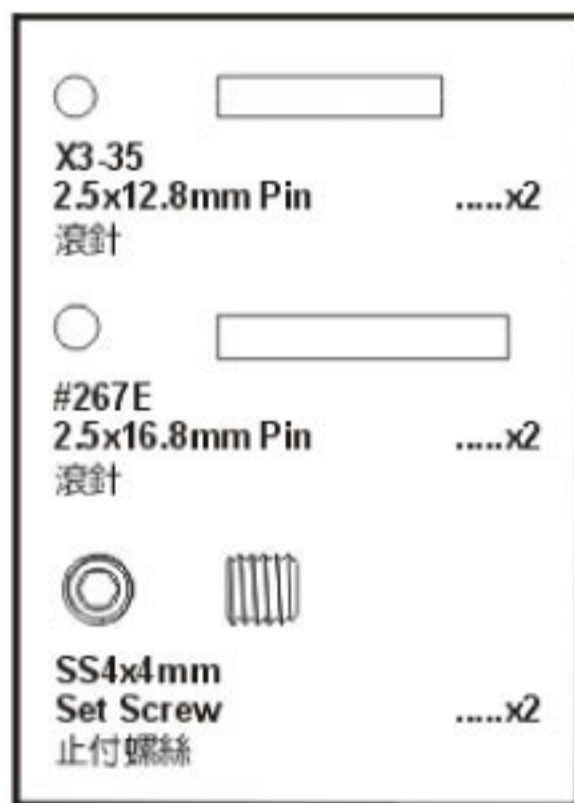

## 14 ASSEMBLY OF THE KNUCKLE ARMS ONTO FRONT LOWER ARMS

組合前轉向座至下擺臂

**BAG** NO.2

Assemble both right and left sides  
請組合左/右兩側。

Step detail  
步驟細節

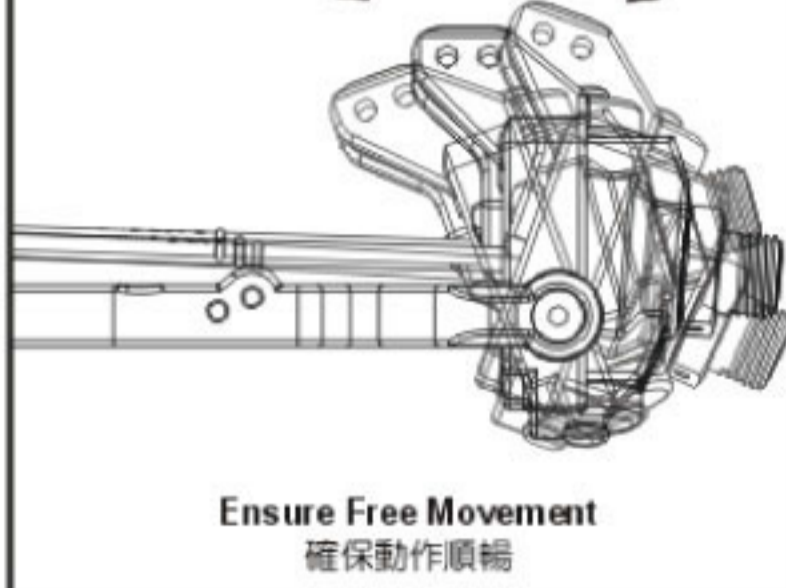
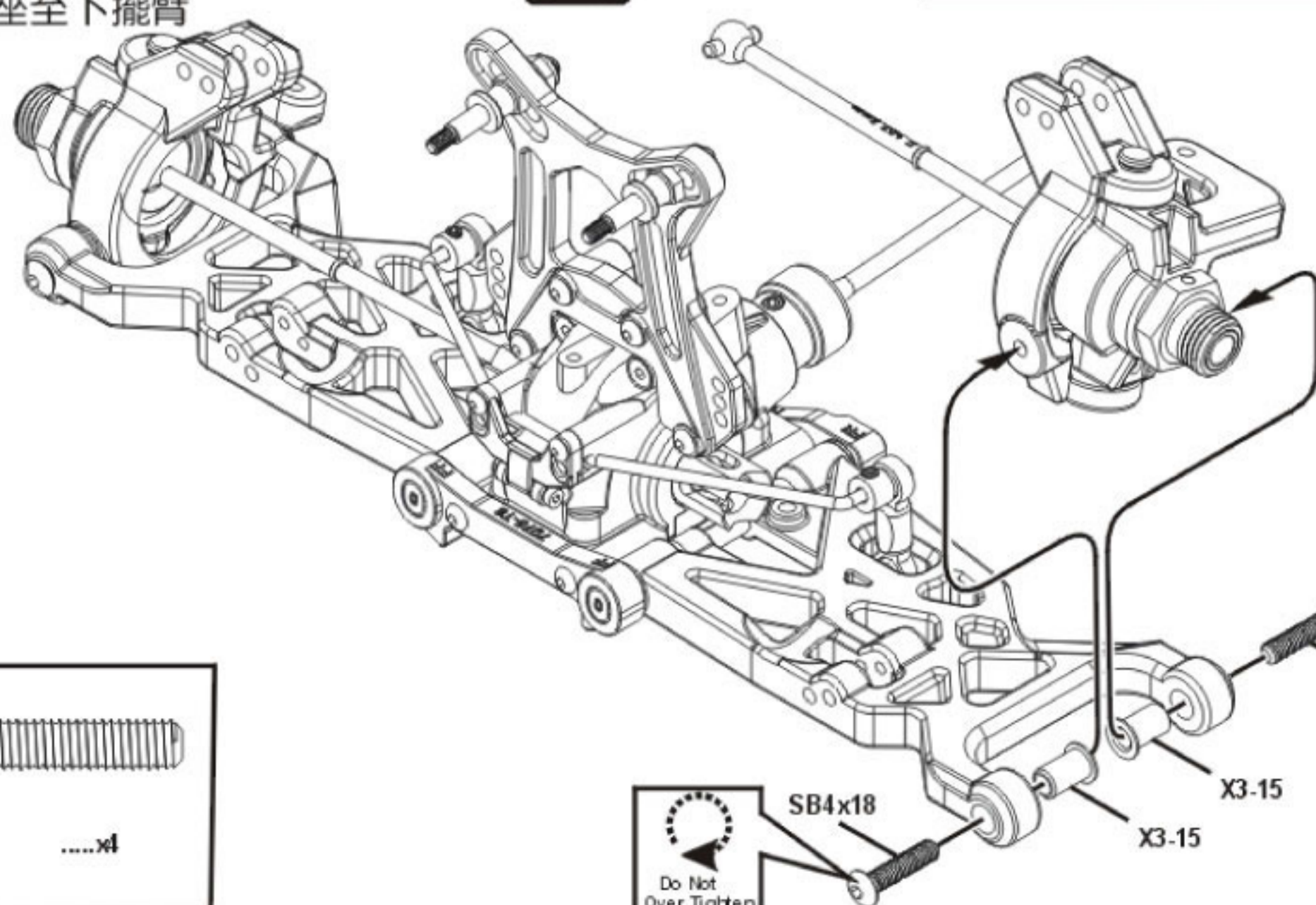
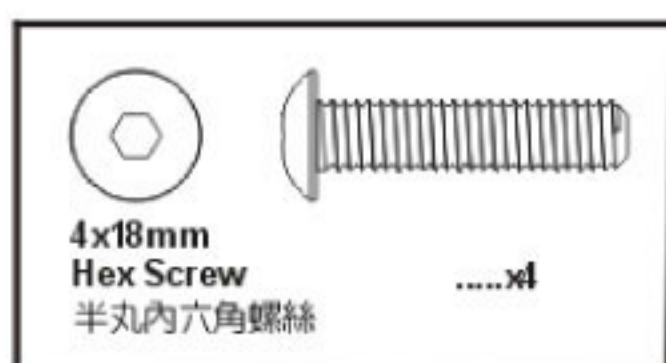



# 15 ASSEMBLY OF THE FRONT UPPER ARMS

前上拉桿組合



Assemble both left and right sides.  
請組合左/右兩側。

**LEFT SIDE**  
左側

- X3-32  
7x12mm Ball  
7x12mm 球型座 .....x2
- G-25  
7mm Ball  
球型 .....x2
- G-26  
5x35mm  
Turnbuckle  
正反牙桿 .....x2

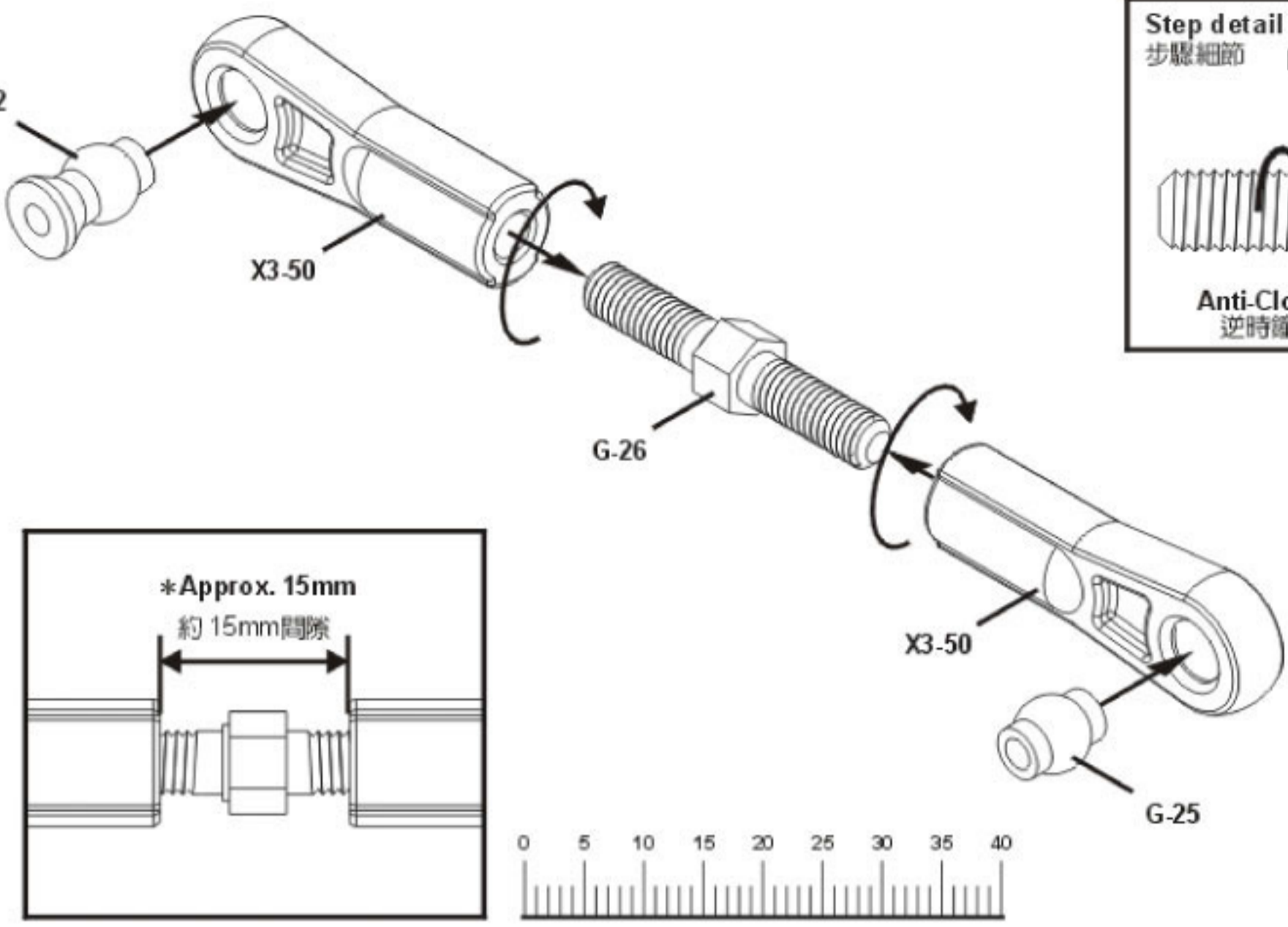

**Step detail**  
步驟細節

Note the locking direction!  
注意鎖緊方向!

Anti-Clockwise  
逆時鐘反牙

Clockwise  
順時鐘正牙

**Step detail**  
步驟細節

Use tools to tighten as shown.  
如圖示使用工具鎖緊。

# 16 ASSEMBLY OF THE FRONT UPPER ARMS

前上拉桿組合



Assemble both right and left sides.  
請組合左/右兩側。

**LEFT SIDE**  
左側

- SNN3mm  
Nylon Nut  
尼龍螺帽 .....x4
- SB3x25mm  
Hex Screw  
半丸內六角螺絲 .....x2
- SB3x20mm  
Hex Screw  
半丸內六角螺絲 .....x2

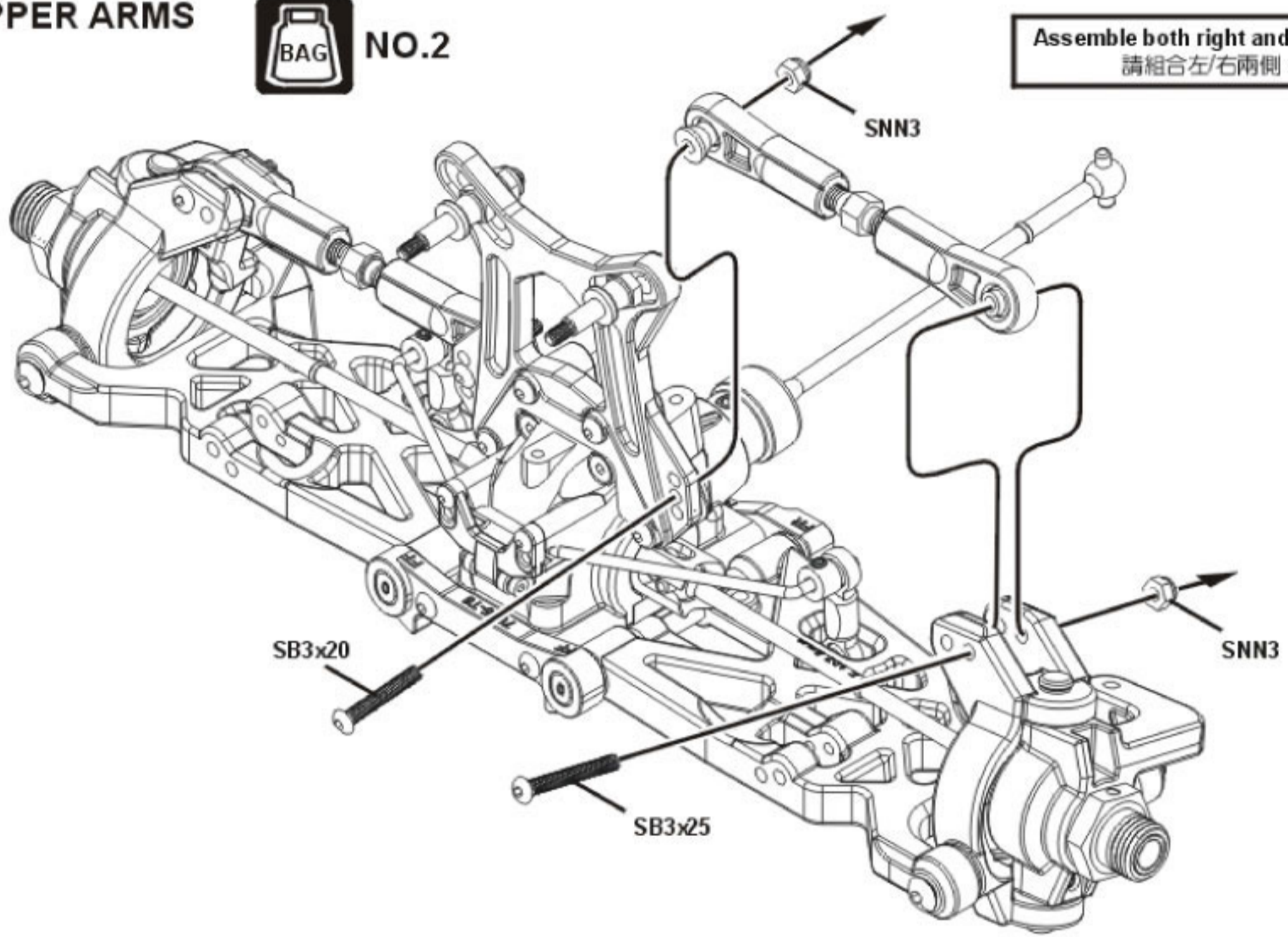

# 17 ASSEMBLY OF THE SERVO SAVER

緩衝組組合



Servo saver spring preload.  
緩衝組彈簧預留

\*Approx. 1mm  
約 1mm 間隙

- X3-21  
Steering Plat  
Hex Screw  
緩衝組螺絲 .....x2
- X3-19  
12x1.7mm O-Ring  
12x1.7mm O環 .....x1
- SNN3mm  
Nylon Nut  
尼龍螺帽 .....x3

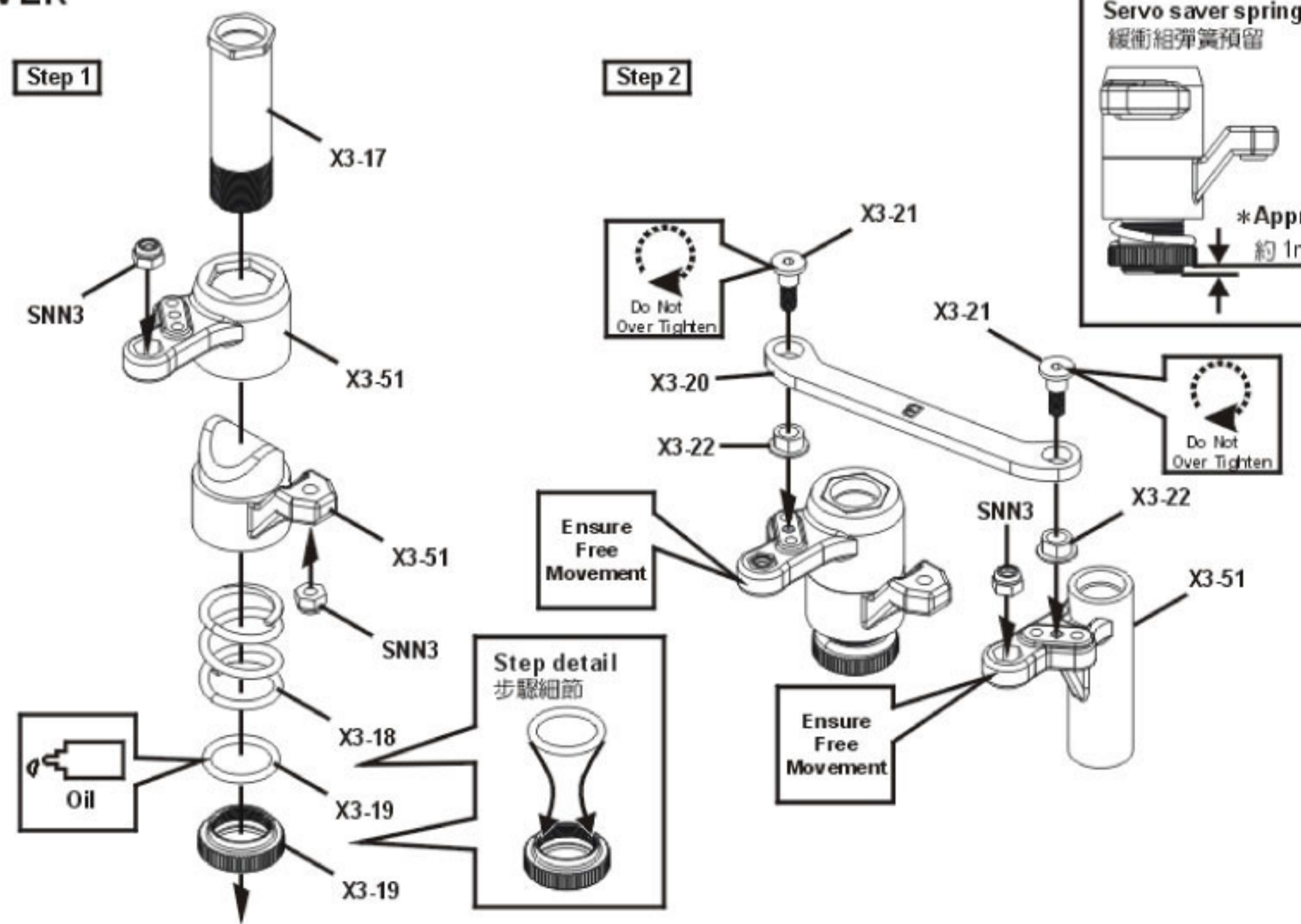



# 18 ASSEMBLY OF THE FRONT PLATE ONTO SERVO SAVER

緩衝組與前三角板組合

**BAG** NO.3

-  **SNN3mm Nylon Nut** 尼龍螺帽 .....x1
-  **SB3x10mm Hex Screw** 半丸內六角螺絲 .....x1
-  **SB3x12mm Hex Screw** 半丸內六角螺絲 .....x3
-  **SW3x6x0.5 Washer** 墊片 .....x2
-  **JS-14B 6x10x3 Ball Bearing** 培林 .....x4

**Step 1**

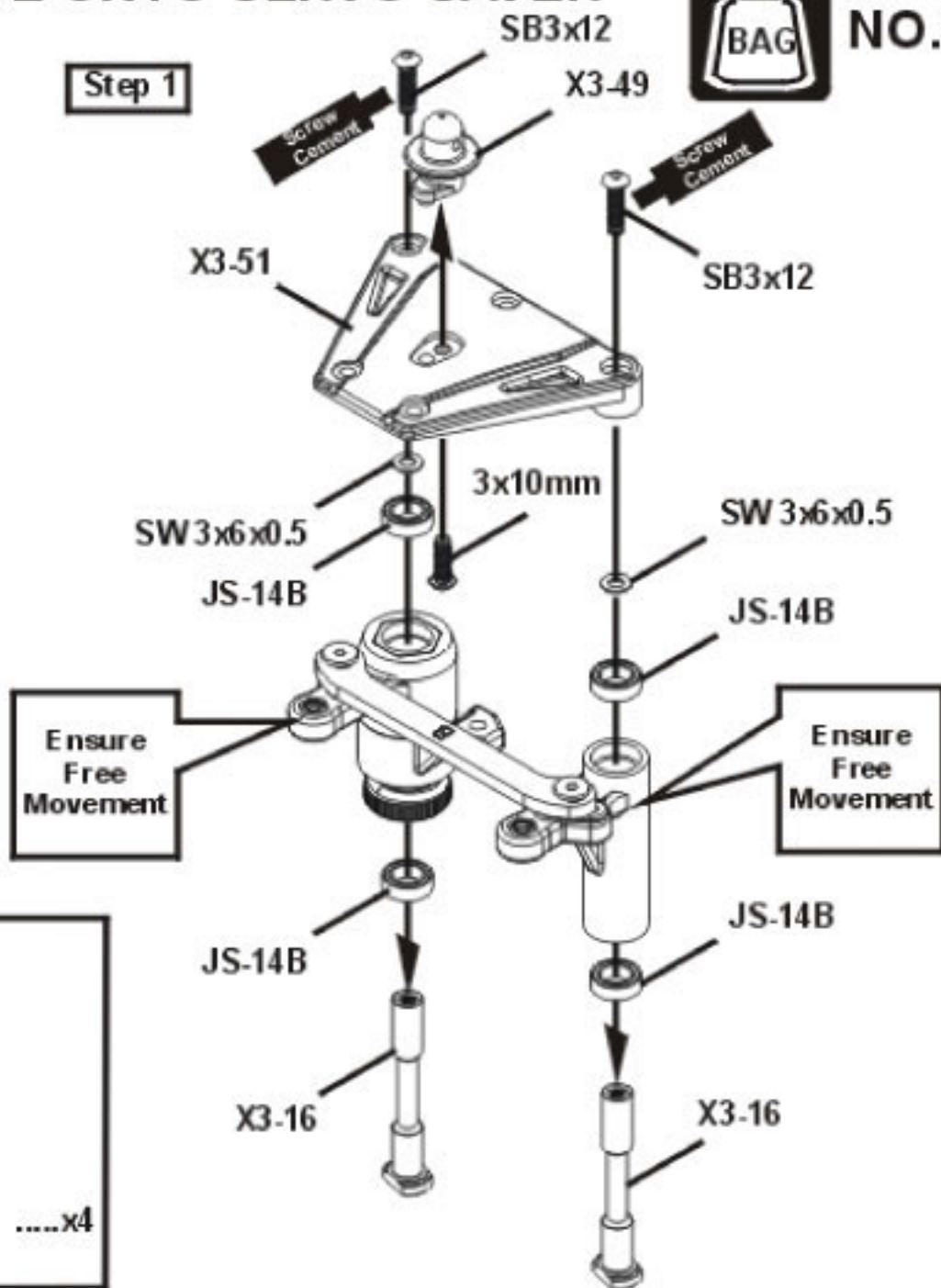

**Step 2**

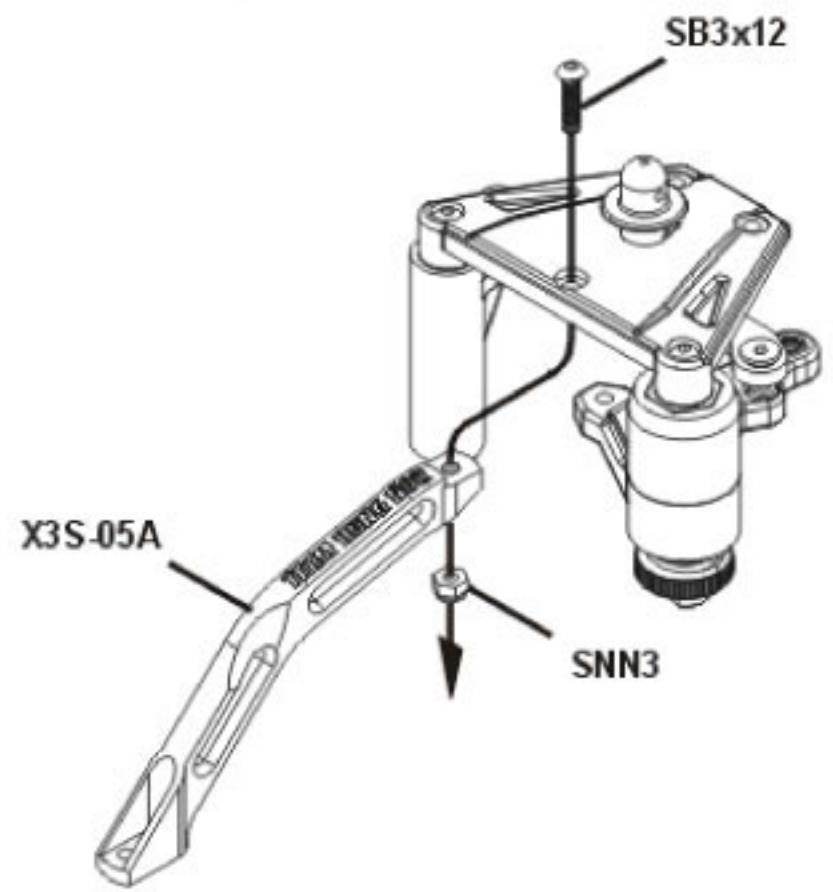

# 19 ASSEMBLY OF THE STEERING TIE-ROD

轉向拉桿組合

**BAG** NO.3

Make two steering rods for left and right hand sides.  
請裝備左邊和右邊2支轉向拉桿。

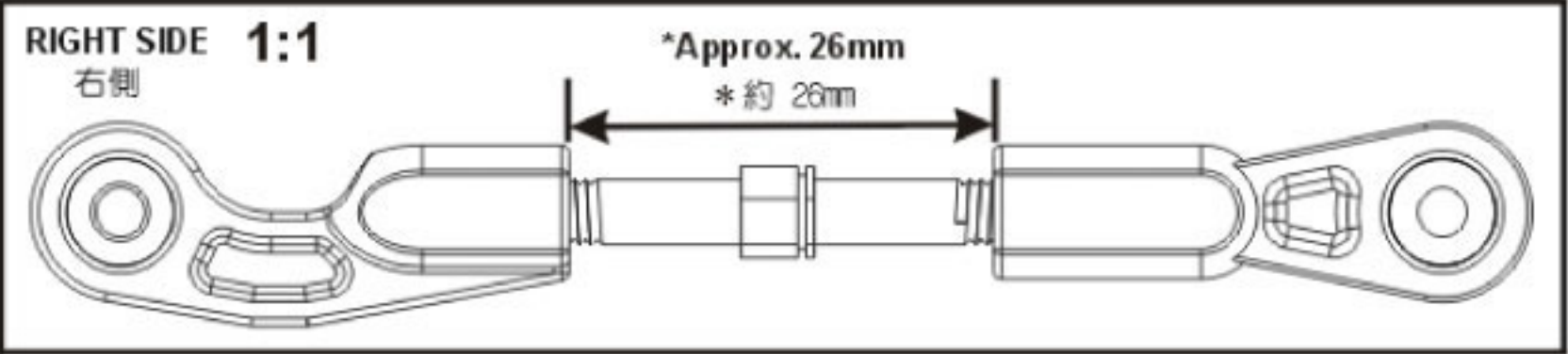
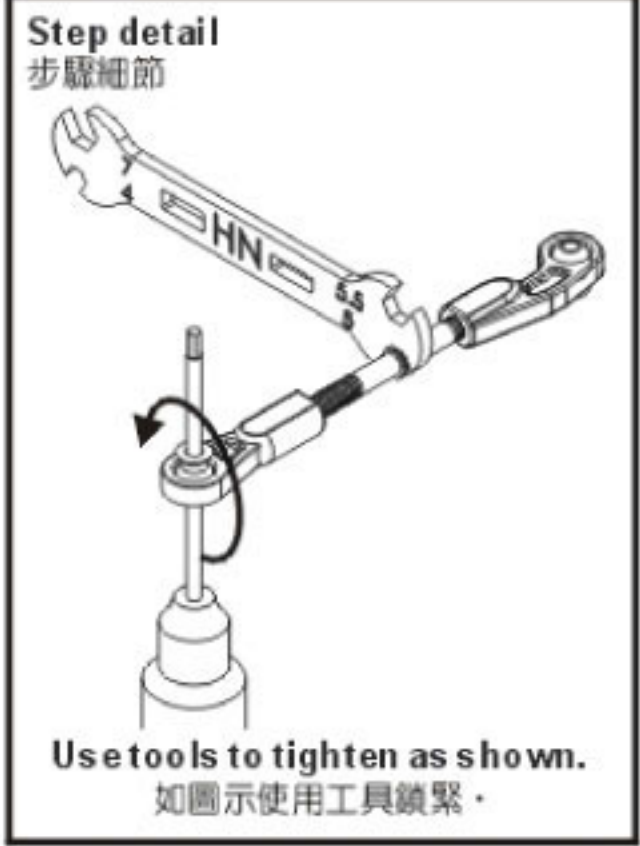
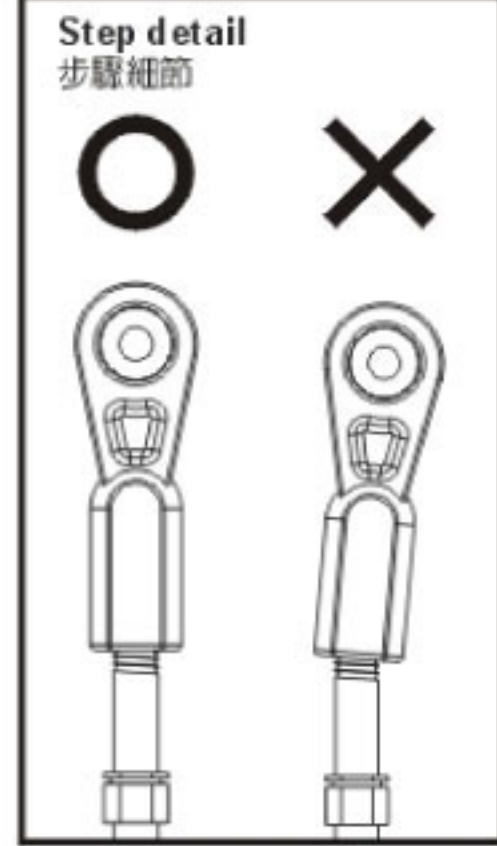
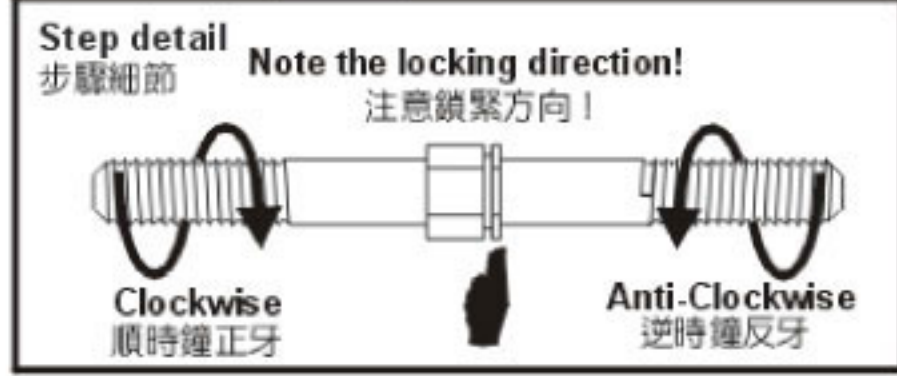
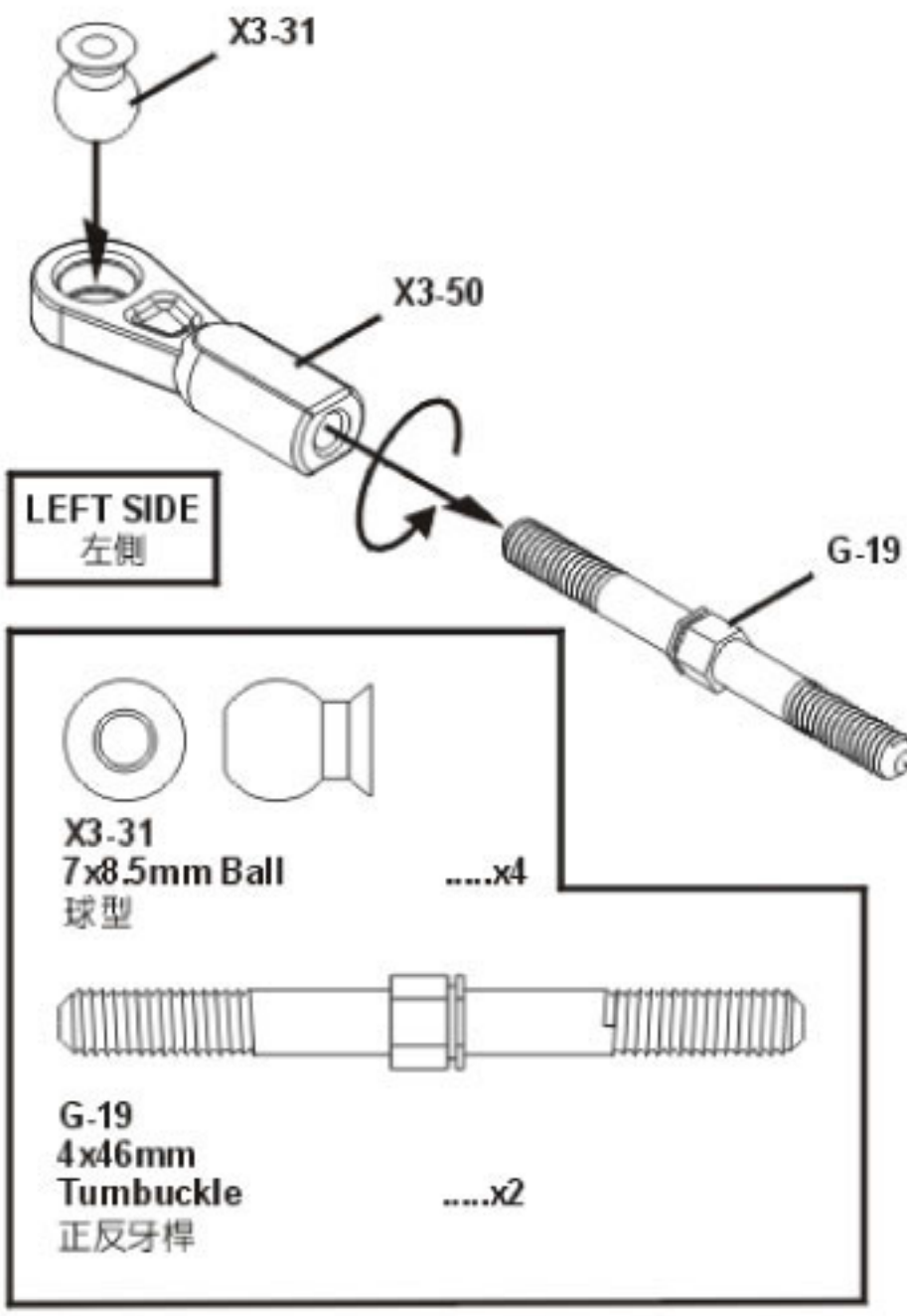

# 20 ASSEMBLY OF THE STEERING TIE-ROD

轉向拉桿組合

**BAG** NO.3

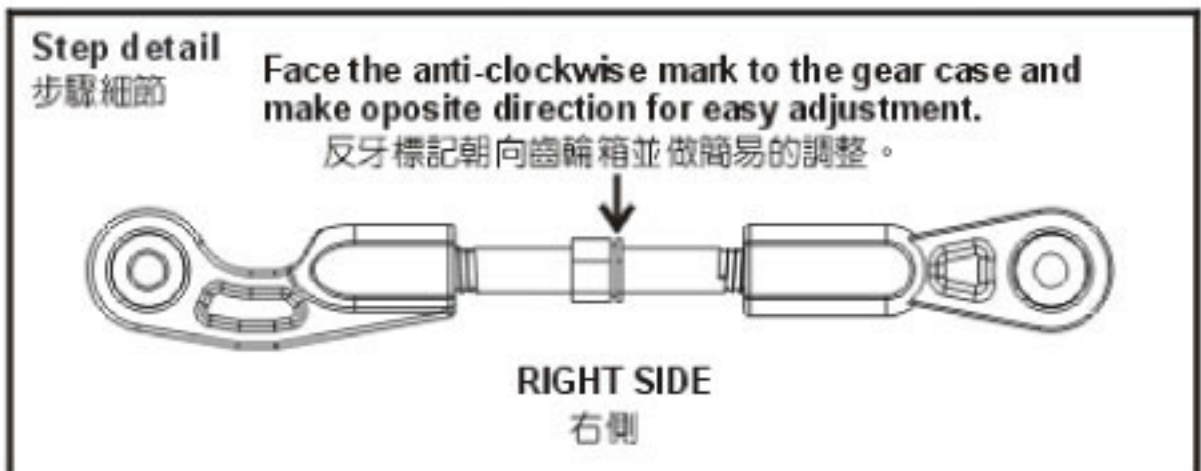

-  **SF3x16mm Flat Head Hex Screw** 皿頭內六角螺絲 .....x2

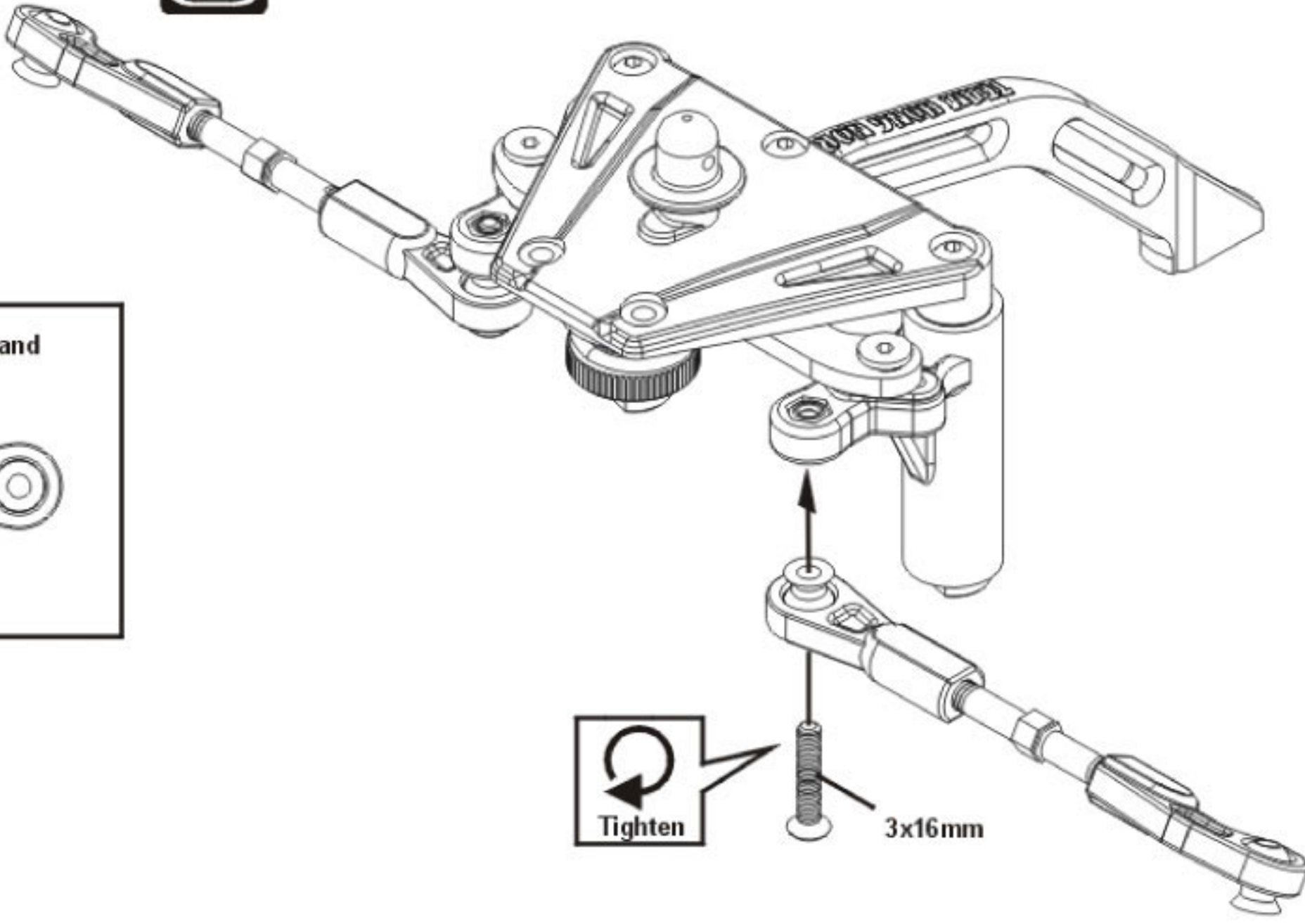



**21 ASSEMBLY OF THE SERVO ONTO THE FRONT GEAR BOX**  
組合緩衝組至前齒輪箱

**BAG NO.3**

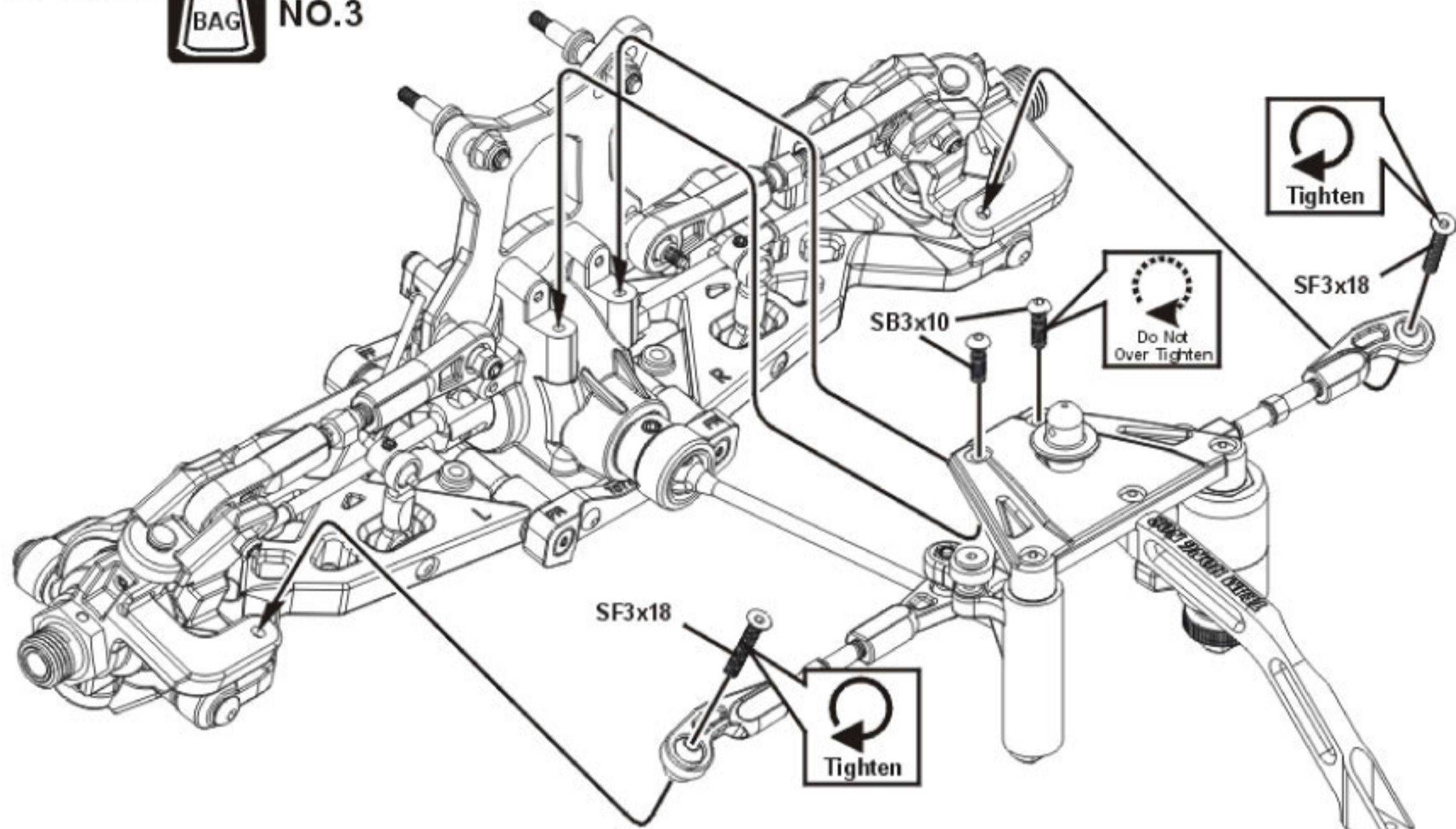

-  SF3x18mm Flat Head Hex Screw .....x2  
皿頭內六角螺絲
-  SB3x10mm Hex Screw .....x2  
半丸內六角螺絲

**22 ASSEMBLY OF THE CENTER/REAR CVD SHAFT**  
中央/後CVD傳動軸組合

**BAG NO.4**

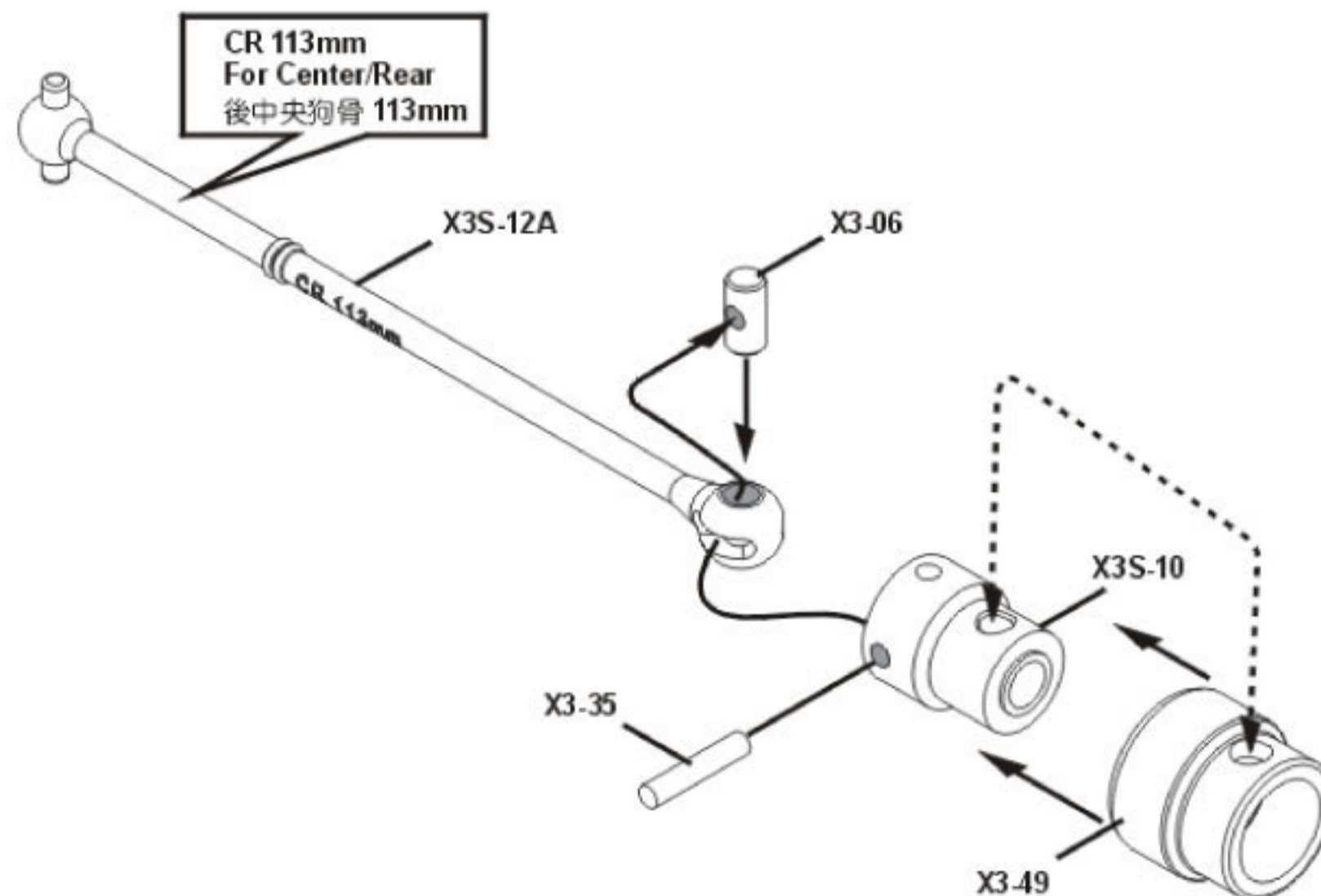



-  X3-35 2.5x12.8mm Pin .....x1  
滾針

**23 ASSEMBLY OF THE REAR GEAR CASE**  
後齒輪箱組合

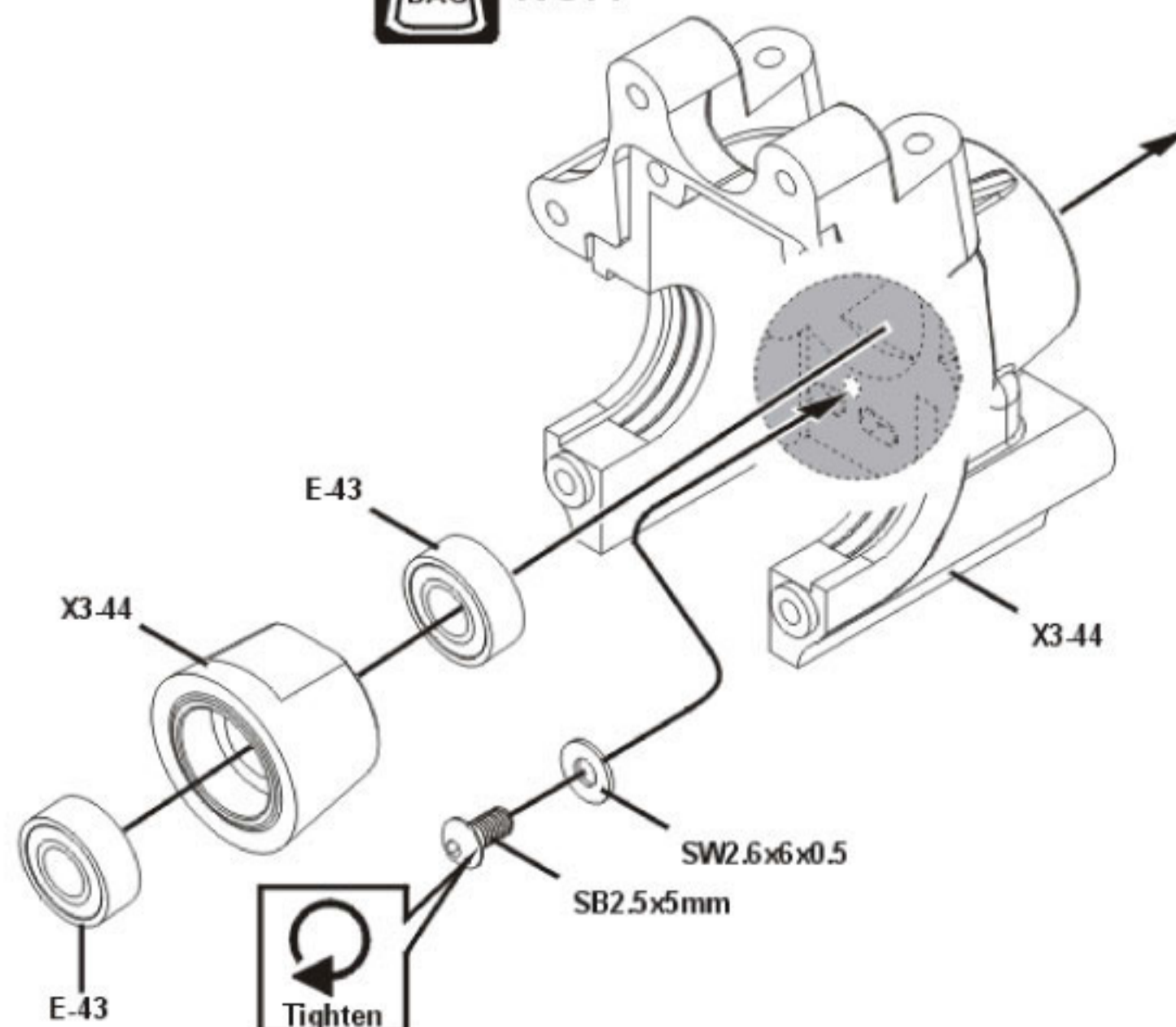
**BAG NO.4**



-  SW2.6x6x0.5 Washer .....x1  
墊片
-  E-43 5x11x4mm Ball Bearing .....x2  
培林
-  SB2.5x5mm Hex Screw .....x1  
半丸內六角螺絲

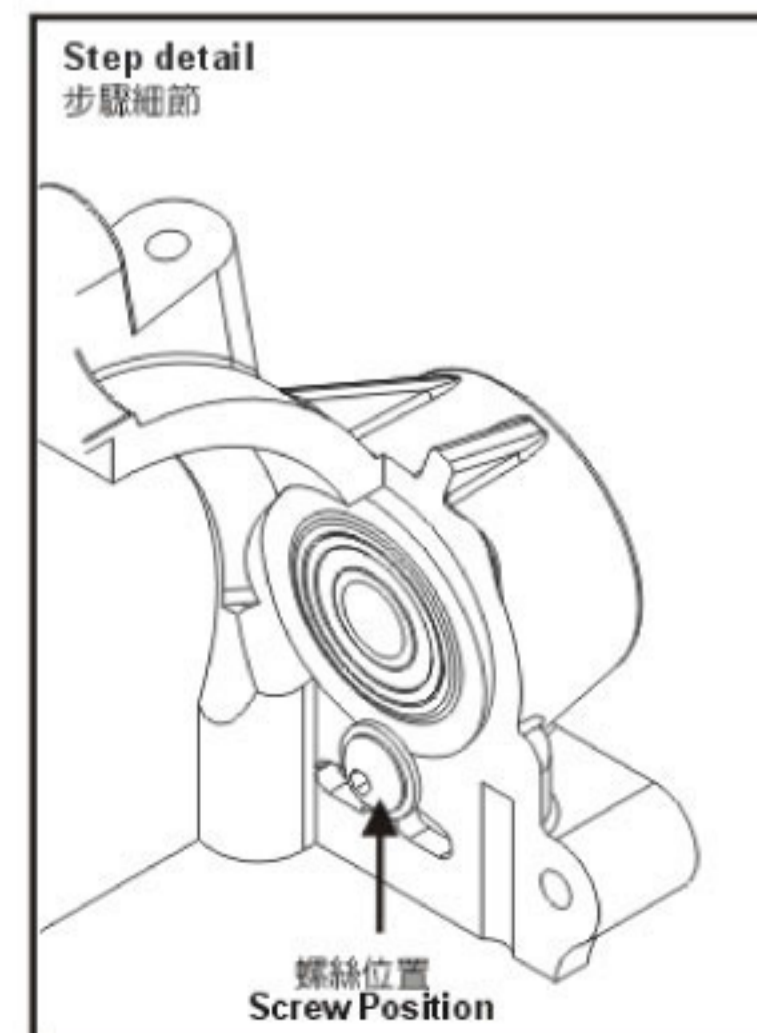



## 24 ASSEMBLY OF THE REAR PINION GEAR AND CVD SHAFT

後小傘齒與CVD傳動軸組合



NO.4

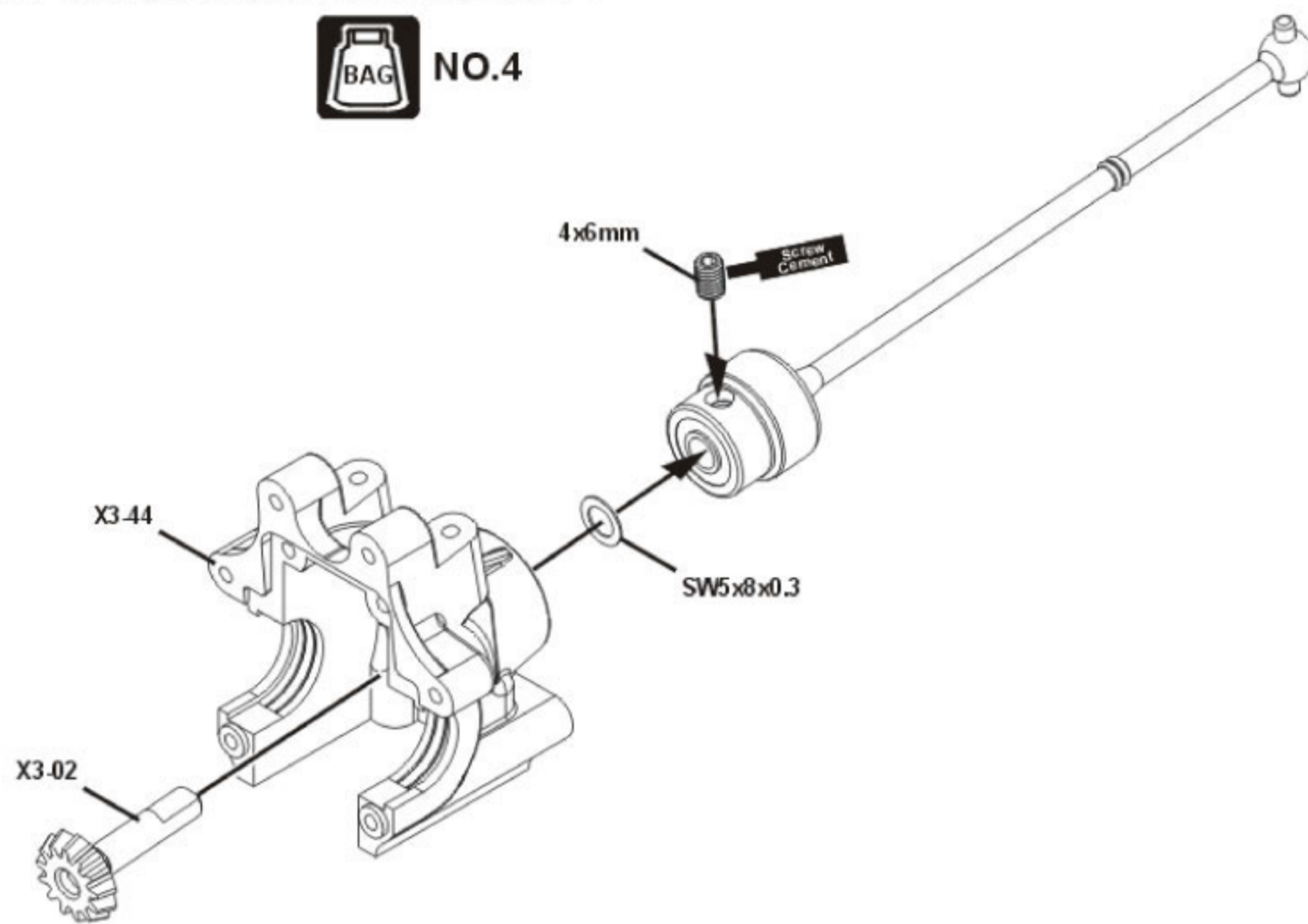

## 25 ASSEMBLY OF THE REAR DIFFERENTIAL ONTO GEAR CASE

後差速器與後齒輪箱組合



NO.4  
NO.1

Adjust the backlash with the Shims.  
請使用墊片調整間隙。

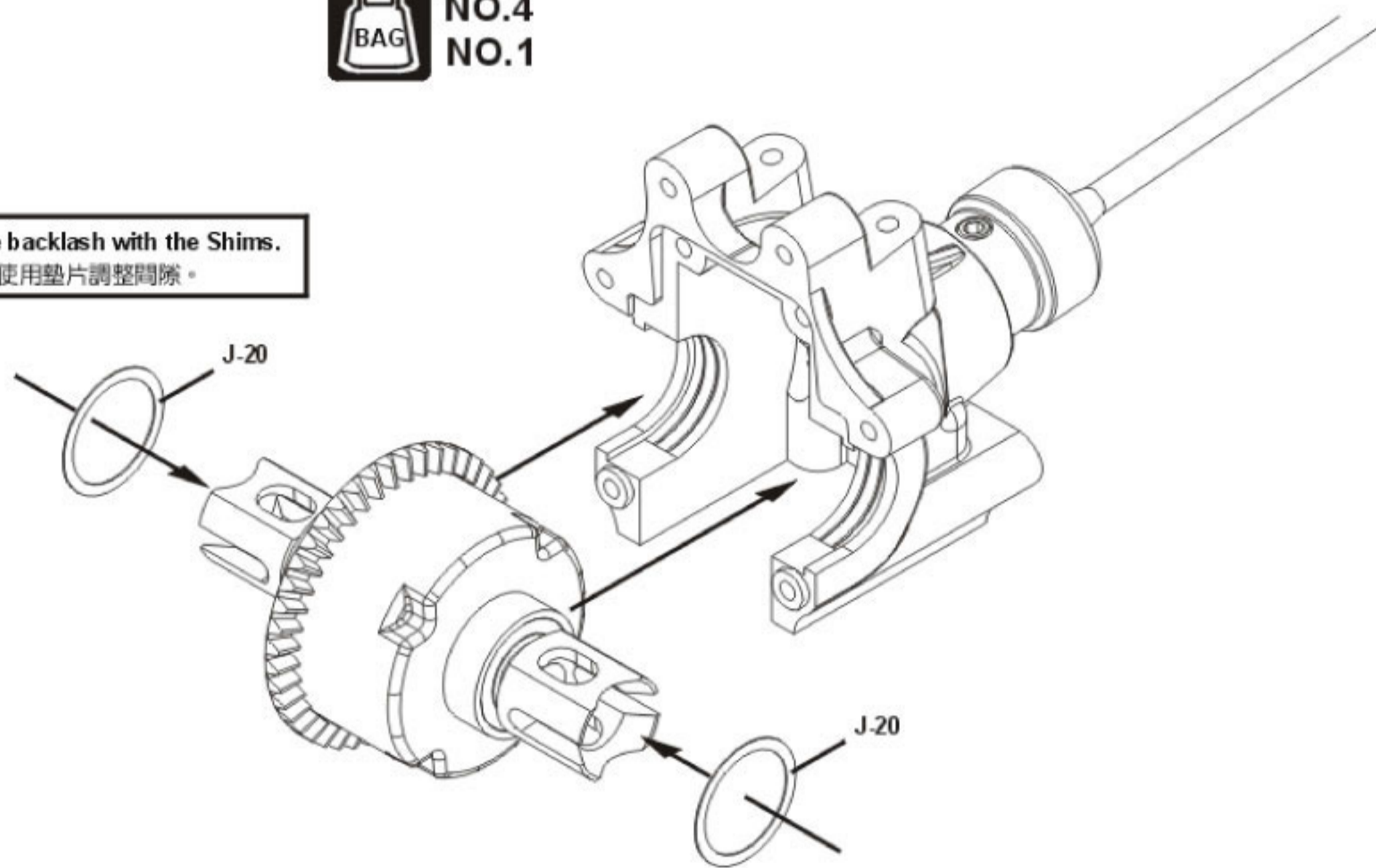

## 26 ASSEMBLY OF THE REAR GEAR CASE COVER AND LOWER ARM HOLDERS

組合後齒輪箱前蓋及後下擺臂固定座



NO.4

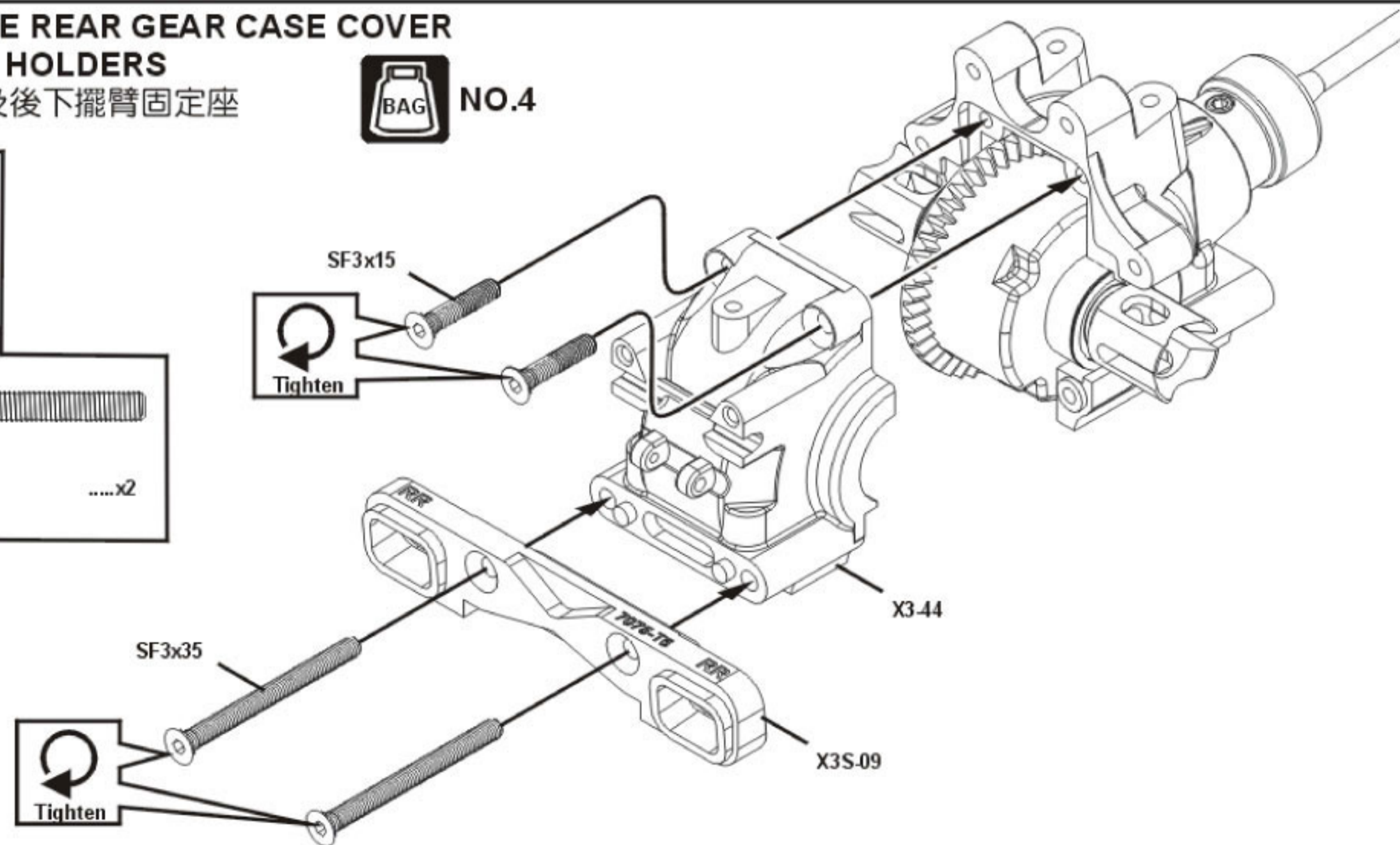
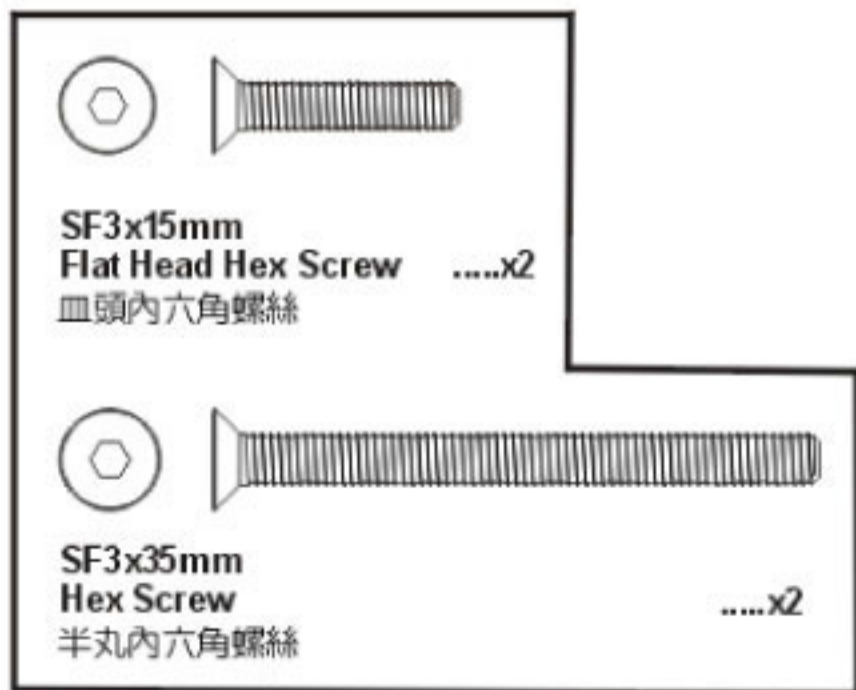



**27 ASSEMBLY OF THE REAR BRACE MOUNT**  
後支撐架座組合

**BAG** NO.2  
NO.4

- SNN4mm Nylon Nut 尼龍螺帽 .....x1
- SB3x12mm Hex Screw 半丸內六角螺絲 .....x2

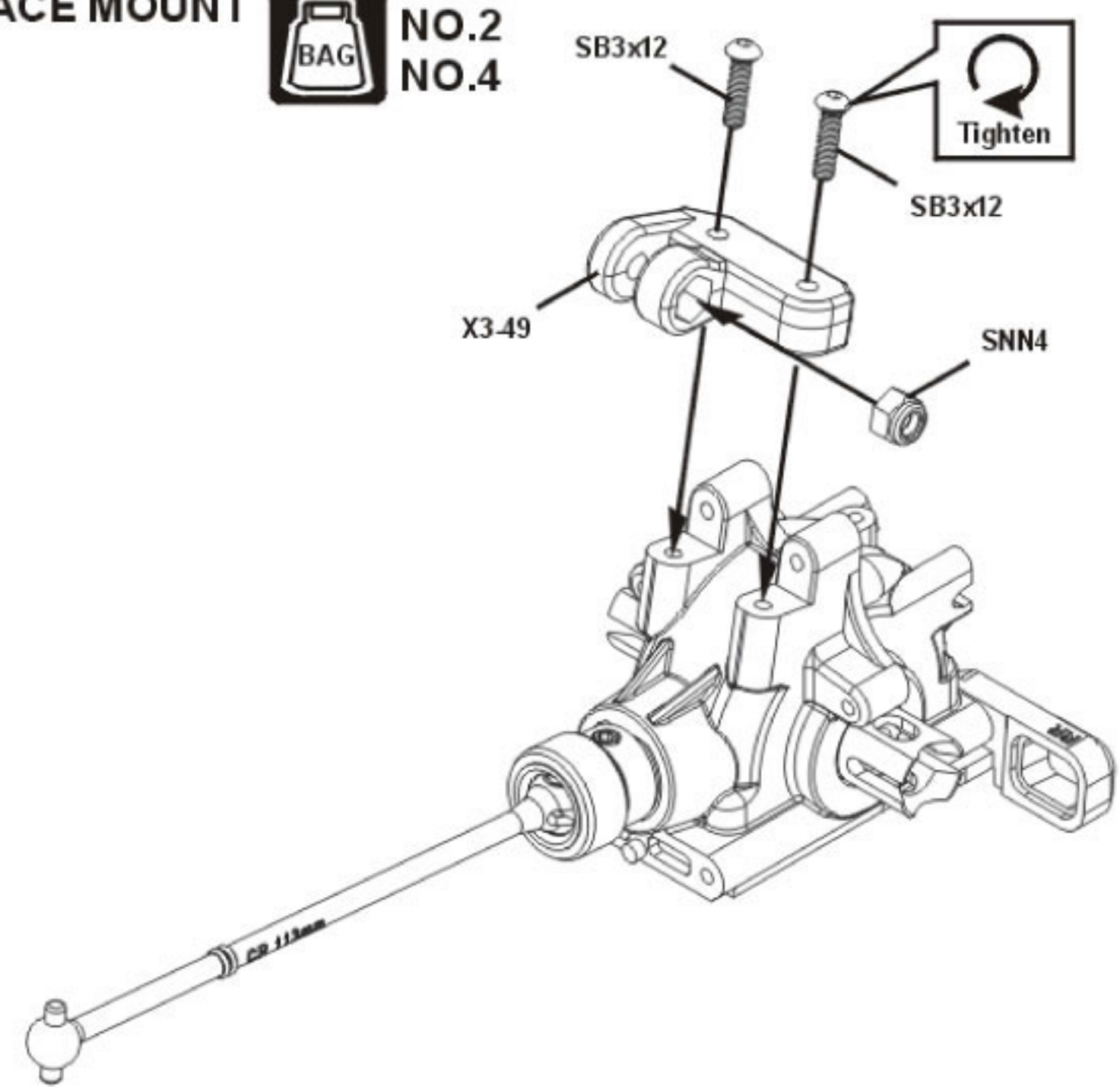

**28 ASSEMBLY OF THE REAR SHOCK STAY**  
後油壓架組合

**BAG** NO.2  
NO.4  
NO.9

- SF3x10mm Flat Head Hex Screw 皿頭內六角螺絲 .....x1
- MK-18 4mm Alum. Nylon Nut 鋁尼龍螺帽 .....x2

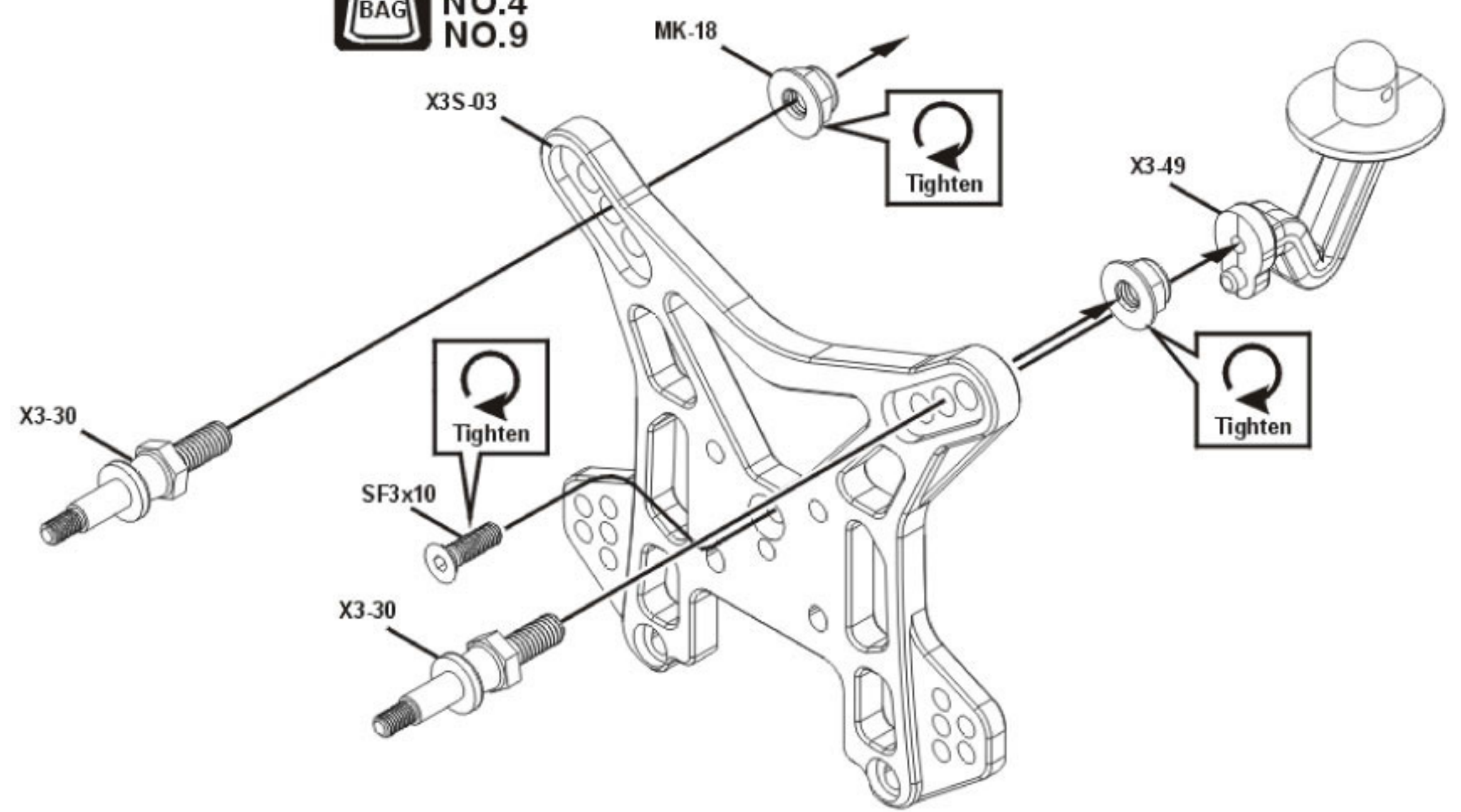

**29 ASSEMBLY OF THE REAR SHOCK STAY ONTO REAR GEAR CASE**  
後油壓架與齒輪箱組合

**BAG** NO.4

- SB3x12mm Hex Screw 半丸內六角螺絲 .....x2

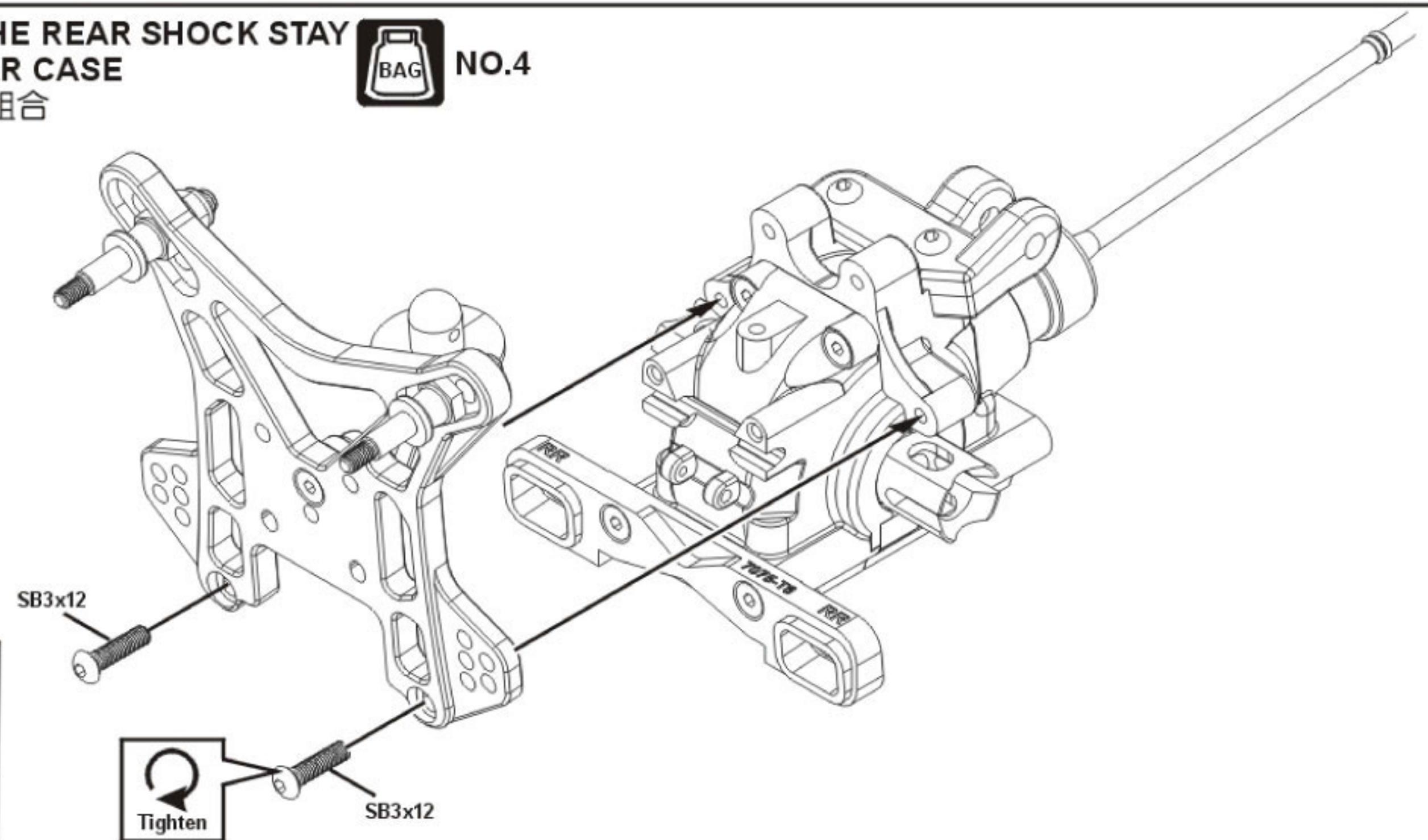



### 30 ASSEMBLY OF THE WING STAY

定風翼架組合

**BAG** NO.4

The angle of the wing mount can become bigger or higher as picture shown.  
定風翼角度如圖示可以裝配位置不同而會有角度及高低變化。

-  **SNN3mm Nylon Nut** 尼龍螺帽 .....x2
-  **SB3x18mm Hex Screw** 半丸內六角螺絲 .....x4
-  **SB3x15mm Hex Screw** 半丸內六角螺絲 .....x2

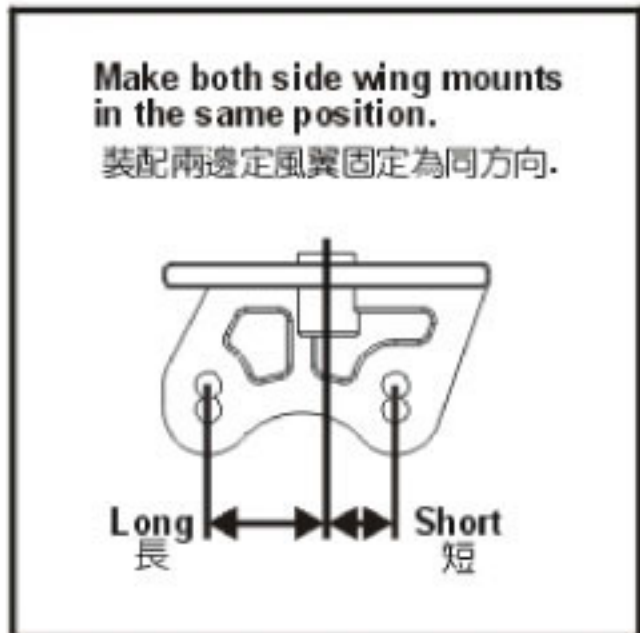
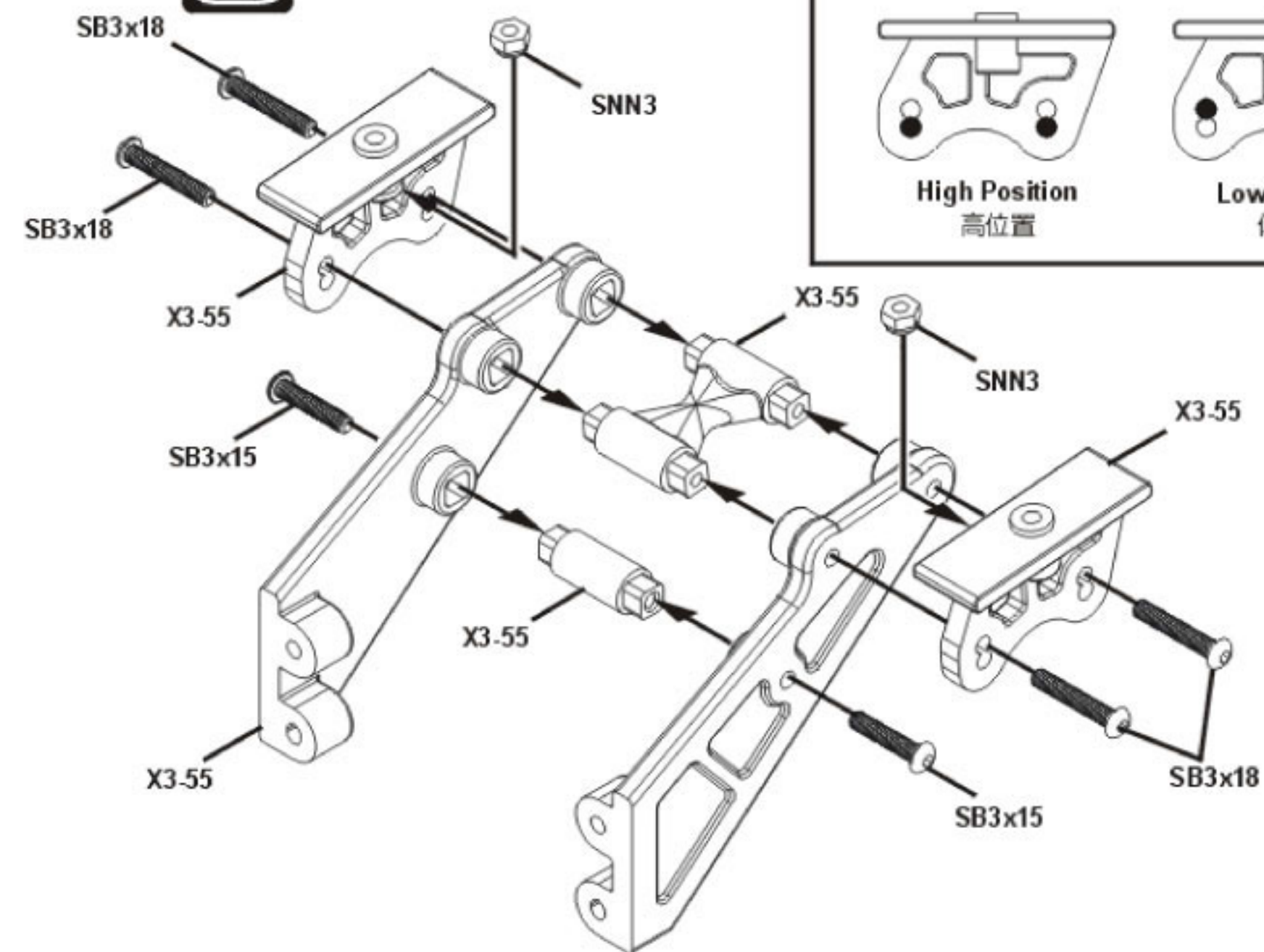

### 31 ASSEMBLY OF THE WING STAY ONTO SHOCK STAY

定風翼架油壓架組合

**BAG** NO.4

-  **SNN3mm Nylon Nut** 尼龍螺帽 .....x2
-  **SB3x18mm Hex Screw** 半丸內六角螺絲 .....x2
-  **SB3x15mm Hex Screw** 半丸內六角螺絲 .....x2

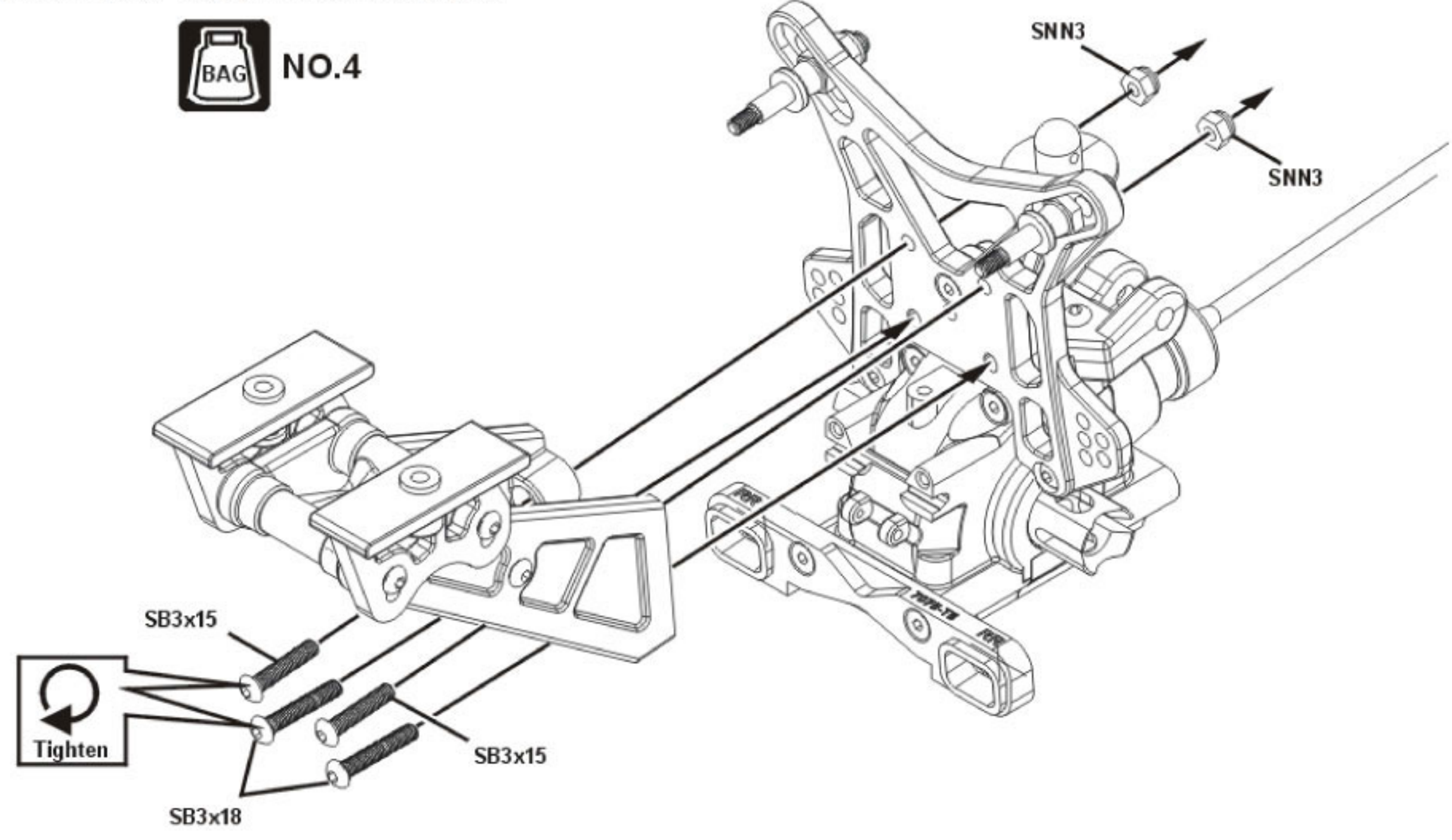

### 32 ASSEMBLY OF THE REAR LOWER ARMS

後齒輪箱與擺臂組合

**BAG** NO.4

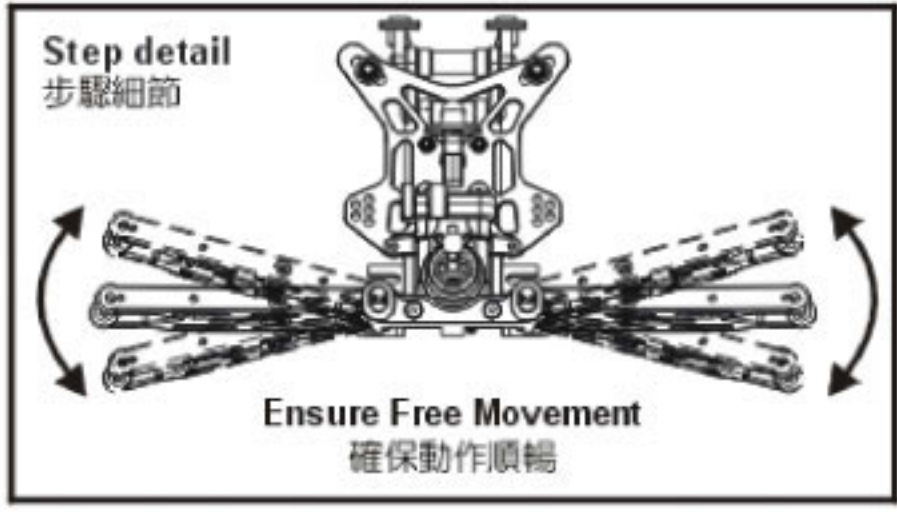

-  **SF3x15mm Flat Head Hex Screw** 皿頭內六角螺絲 .....x2
-  **X3-40 4x10mm Round Head Set Screw** 圓頭止付螺絲 .....x2

**Assemble both right and left side.**  
請組合左/右兩側。

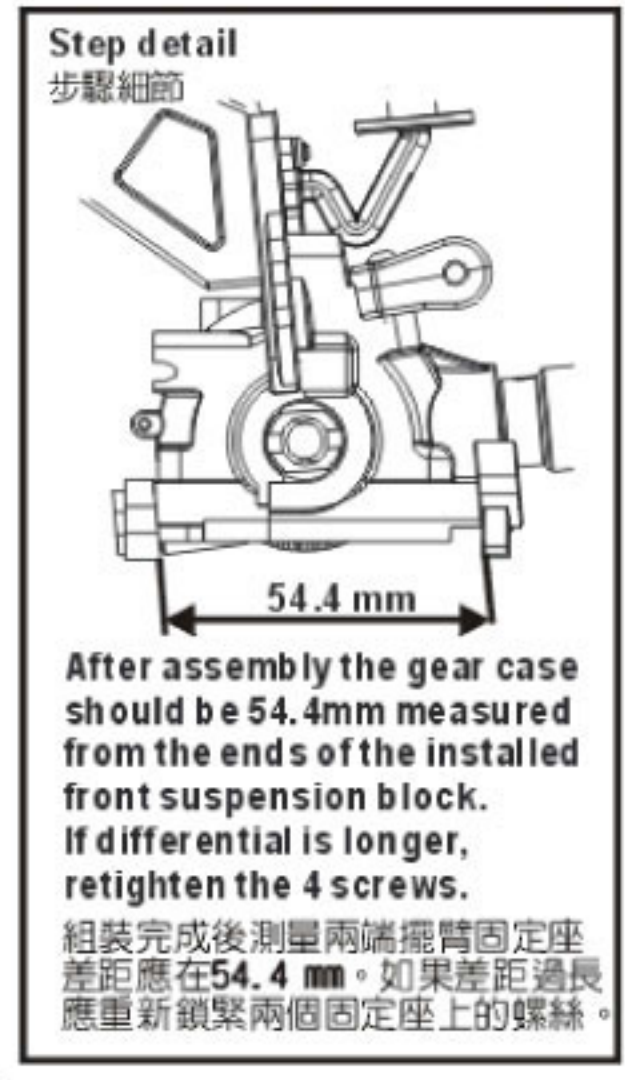
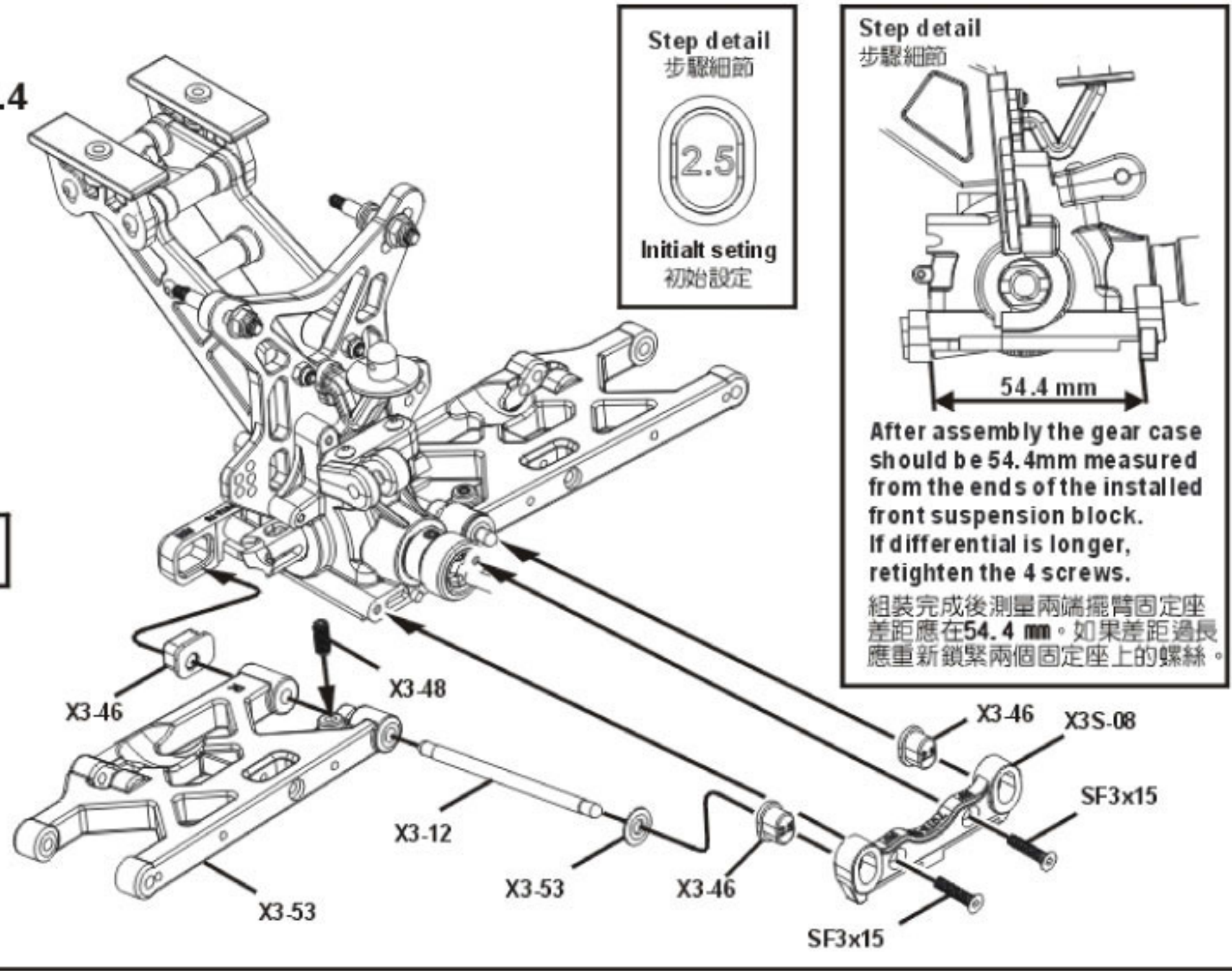
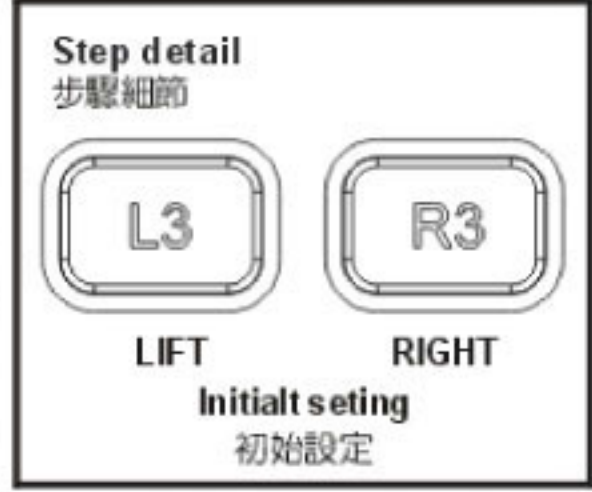



### 33 ASSEMBLY OF THE REAR STABILIZER 後平衡桿組合

BAG NO.4

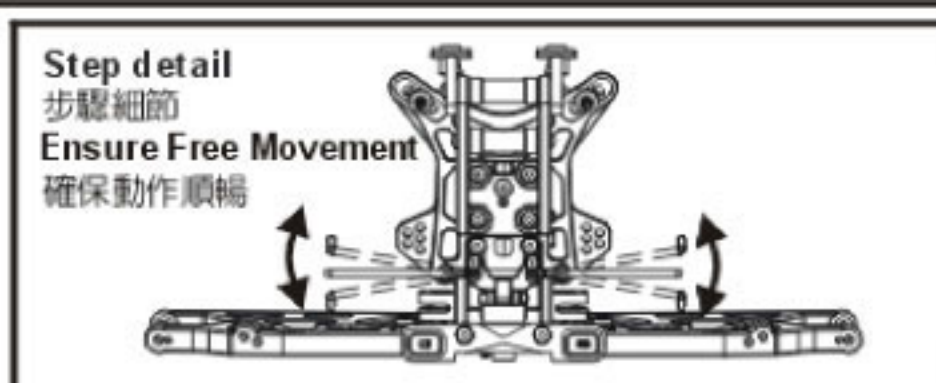

- SB2.5x8mm Hex Screw  
半丸內六角螺絲 .....x2
- SC2x12mm Cap Screw  
有頭內六角螺絲 .....x1
- SB3x18mm Hex Screw  
半丸內六角螺絲 .....x2
- SS3x3mm Set Screw  
止付螺絲 .....x4

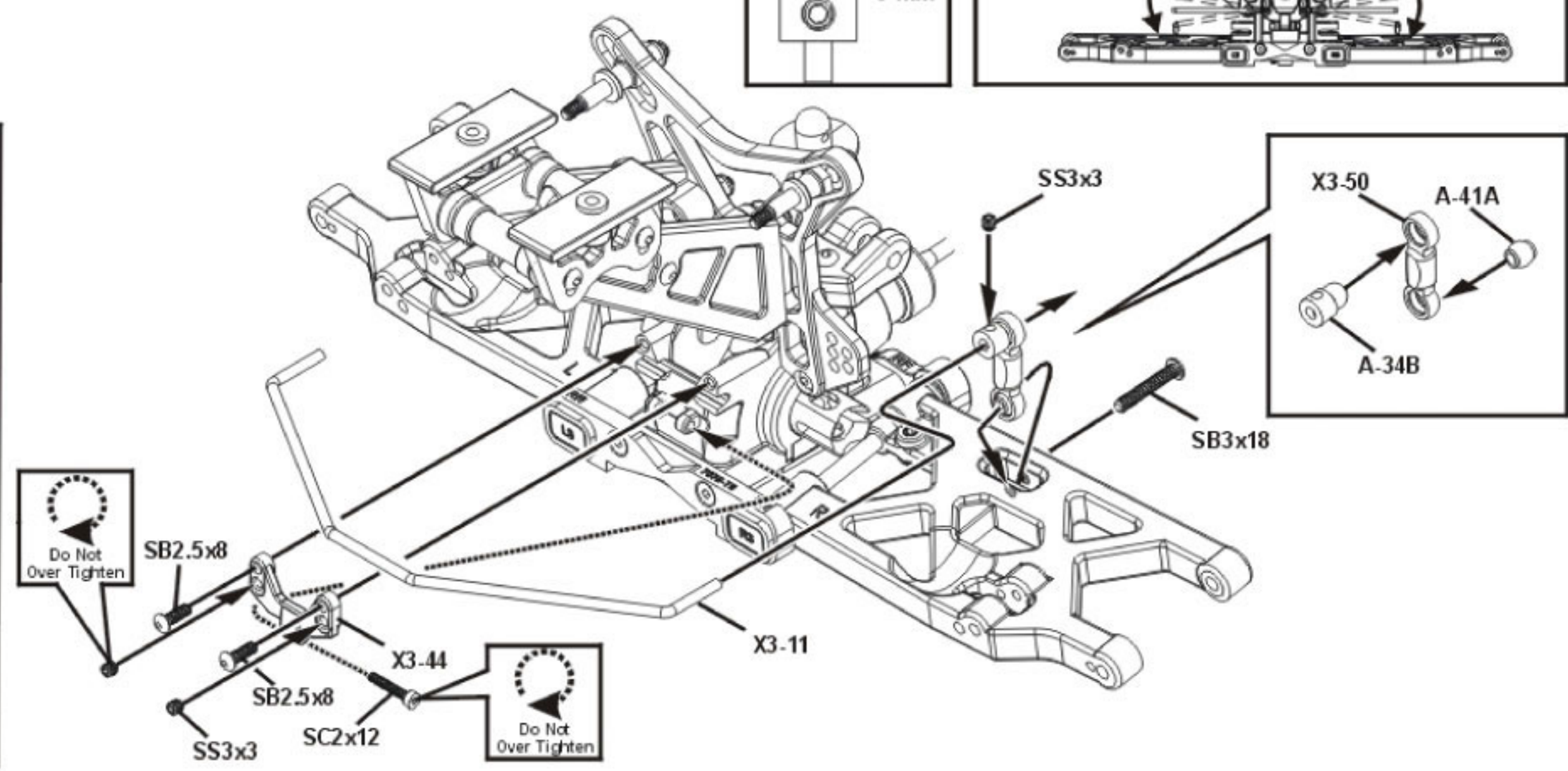

### 34 ASSEMBLY OF THE REAR WHEEL HUBS 後輪座組合

BAG NO.4

Assemble both right and left side.  
請組合左/右兩側。

- X3-35 2.5x12.8mm Pin  
滾針 .....x2
- #267E 2.5x16.8mm Pin  
滾針 .....x2
- 4x4mm Set Screw  
止付螺絲 .....x2

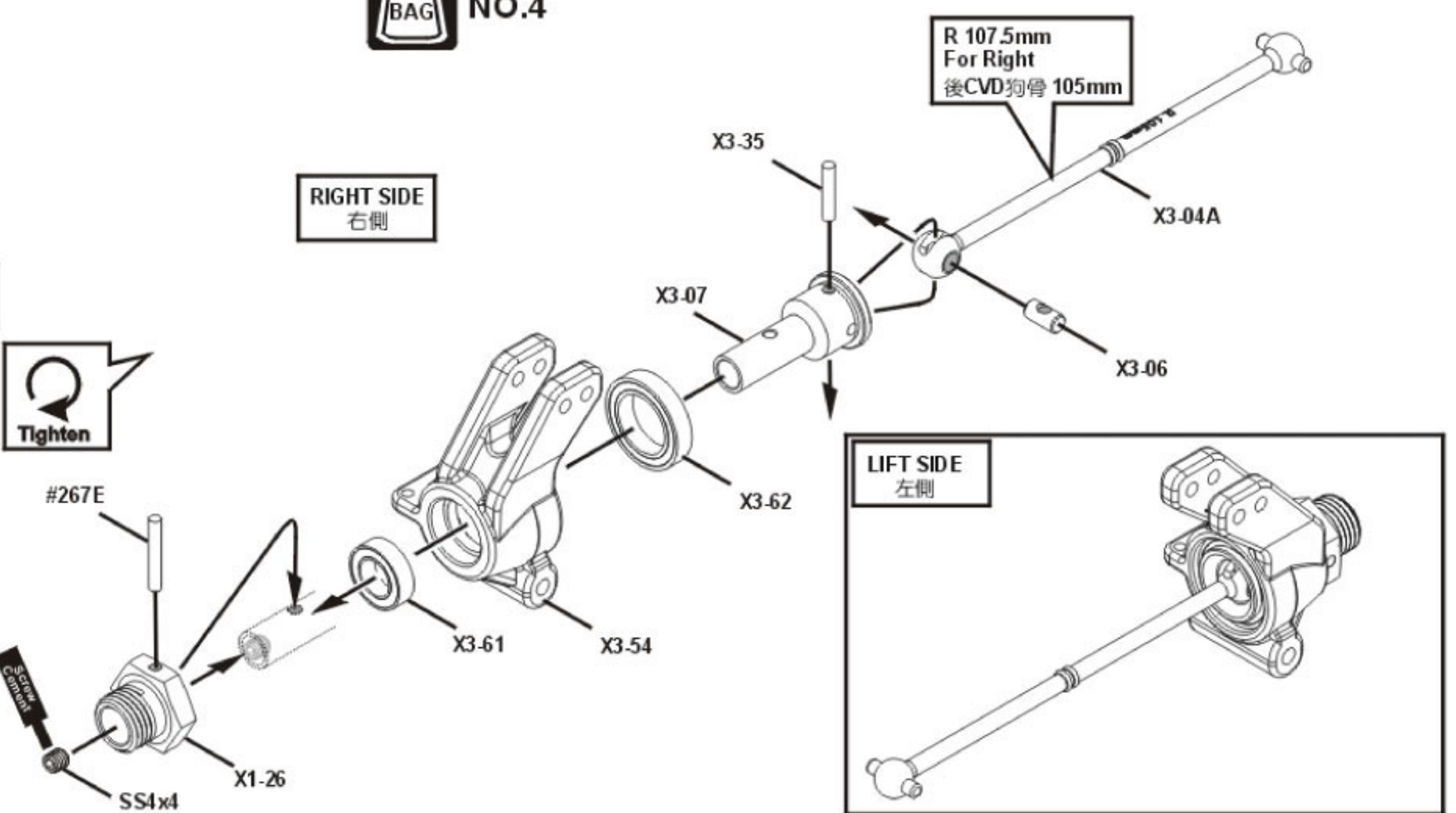

### 35 ASSEMBLY OF THE REAR SUSPENSION ARMS 後懸吊系統組合

BAG NO.4

Assemble both right and left side.  
請組合左/右兩側。

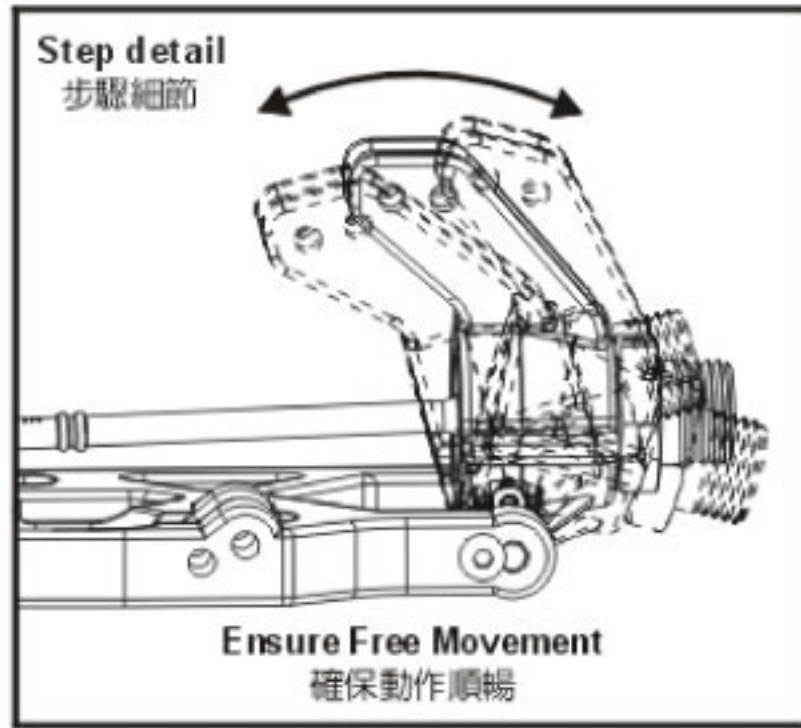

- SB3x5mm Hex Screw  
半丸內六角螺絲 .....x4

