

SCRT10 Set-Up Sheet

Date: _____

Driver: _____

Track: _____ / _____

Air Temp: _____ 80F _____

Surface Dsc. _____ WATERED & DRY _____

Avg. Lap Time: _____ "

Front Suspension

Shock Spring: _____ Gray _____

Shock Piston: / /

Shock Oil wt: _____

Shock Length: _____ mm
(Center to Center)

Toe-IN: _____

Toe-Out: _____

Front Ride Height: _____

Sway Bar: _____ None _____

Camber: Neg: _____

Pos: _____

Caster Angle:



(F/F)

F/F	<input type="checkbox"/>	<input type="checkbox"/>	<input type="checkbox"/>
F/R	<input type="checkbox"/>	<input type="checkbox"/>	<input type="checkbox"/>
	22	21	20
	23	22	21
	24	23	22



(F/R)

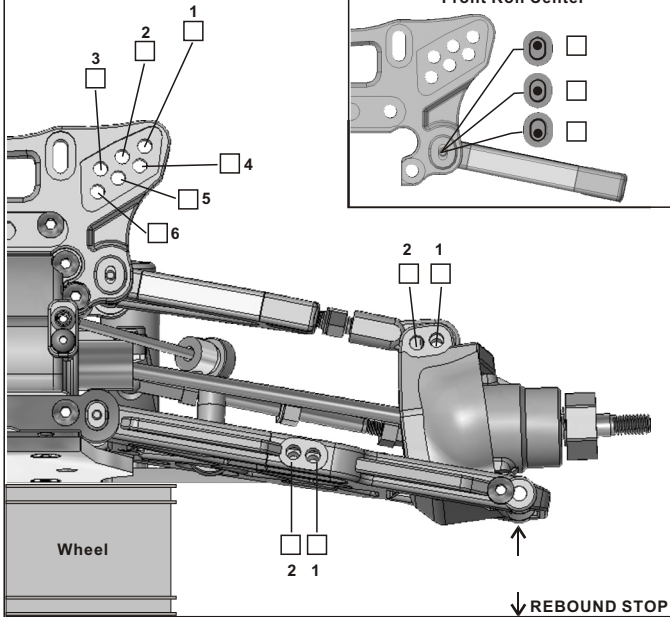

Steering Ackerman Location

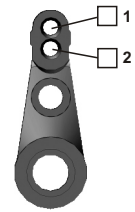

Front Sway Bar Preload

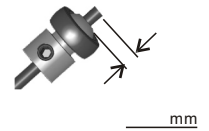

Notes: _____

Rear Suspension

Shock Spring: _____ Gray _____

Shock Piston: / /

Shock Oil wt: _____

Shock Length: _____ mm
(Center to Center)

Rear Ride Height: _____ mm

Sway Bar: _____ None _____

Camber: Neg: _____

Pos: _____

Anti-Squat Plate



R/F

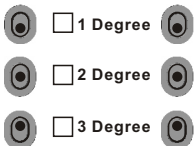

(Right = Left)

Rear Toe-In Plate



R/R

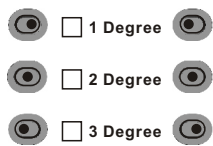

(Right = Left)

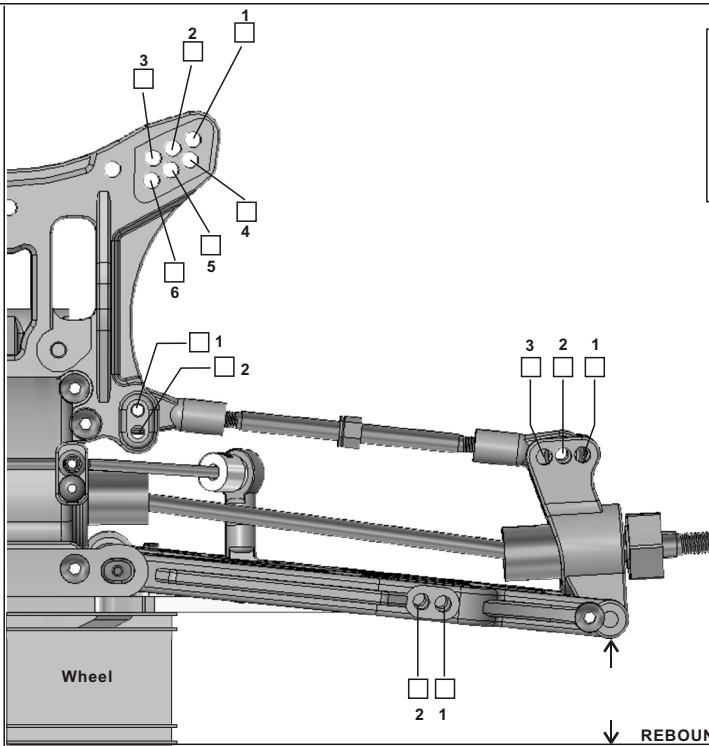

Front Sway Bar Preload

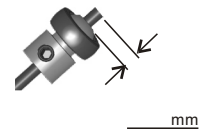

Wheelbase

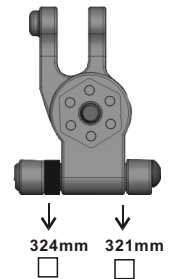

Differential

Oil Type: Silicon Grease

Front: STD-5K _____ K

Center: STD-7K _____ K

Rear: STD-1K _____ K

Tires

Front: STD

Rear: STD

Foam: STD

Others: Brand: _____

Type: _____

Insert: Foam _____

ELECTRIC MOTOR

Type: Brush Brushless

Turn: _____ Turn: _____

RPM: _____ KV: _____

Brand: _____

ELECTRIC SPEED CONTROLLER

Brand: _____

Type: _____

GEAR

Super Gear: 46 T

Motor Gear: _____ T

Gear Brand: STD Other: _____