

X2-CR Set-Up Sheet

Driver: _____

Track: _____ / _____

Air Temp: _____ 80F _____

Track Size	Traction	Surface
<input type="checkbox"/> open	<input type="checkbox"/> High	<input type="checkbox"/> Smooth
<input type="checkbox"/> Medium	<input type="checkbox"/> Medium	<input type="checkbox"/> Medium
<input type="checkbox"/> Tight	<input type="checkbox"/> Low	<input type="checkbox"/> Bumpy

Front Suspension

Shock Spring: _____ Blue _____
 Shock Piston: Standard Drilled
 Shock Oil wt: _____ 50 _____
 Shock Length
 (Center to Center) _____ 105.5mm _____
 Toe-IN: _____
 Toe-Out: _____
 Front Ride Height: _____ mm
 Sway Bar: 2mm 2.3mm 2.5mm
 Camber: Neg: _____
 Pos: _____
 Caster Block: A/A B/B

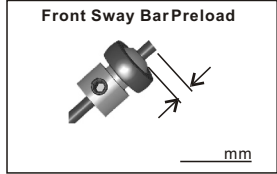
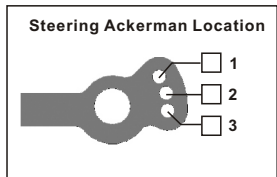
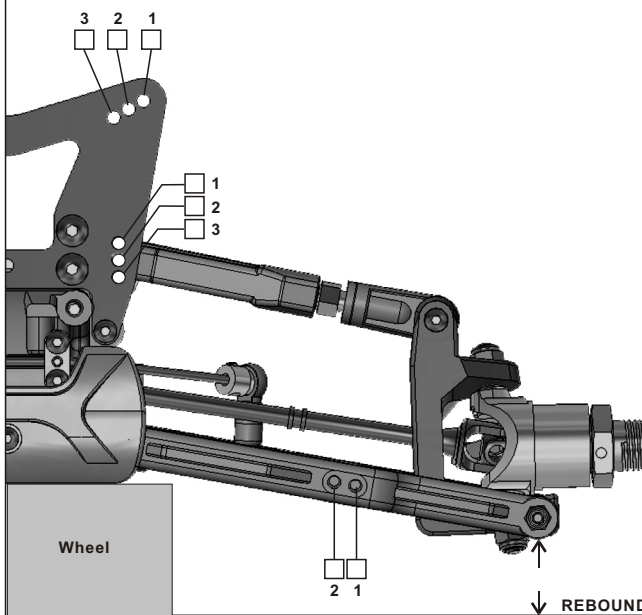
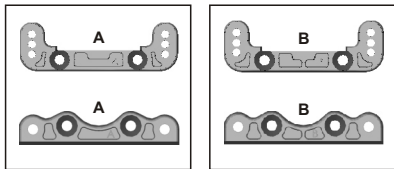

Notes: _____

Rear Suspension

Shock Spring: _____ Blue _____
 Shock Piston: Standard Drilled
 Shock Oil wt: _____ 50 _____
 Shock Length
 (Center to Center) _____ 123.5mm _____
 Rear Ride Height: _____ mm
 Sway Bar: 2.3mm 2.5mm 2.8mm
 _____ None
 Camber: Neg: _____
 Pos: _____
 Rear Hub/Wheelbase: Forward Middle
 Back

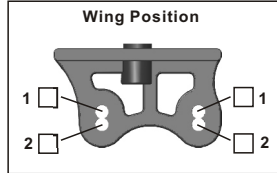
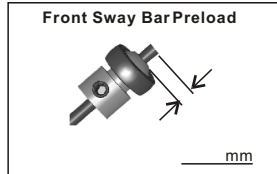
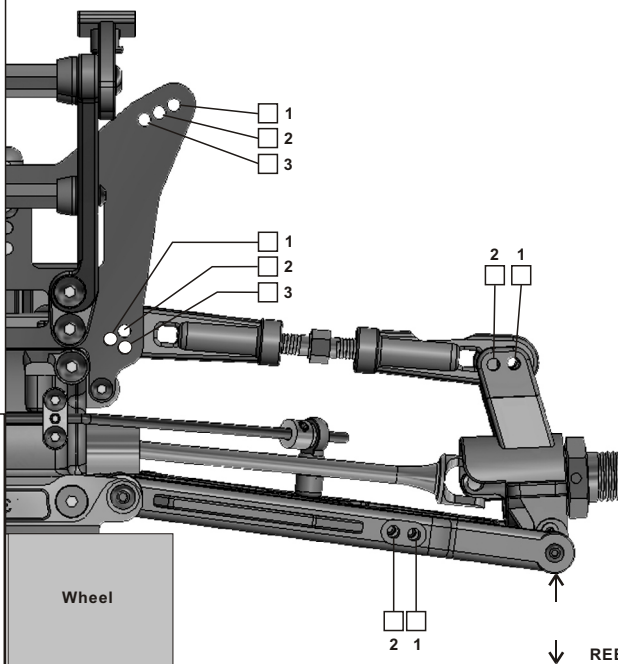
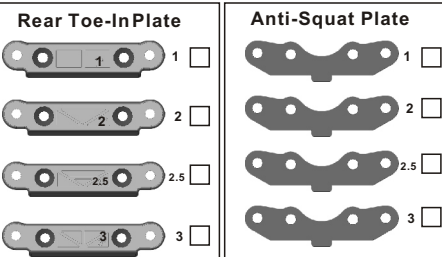

Differential

Front Type: STD Torsen Oil _____ K
 Center Type: STD Torsen Oil _____ K
 Rear Type: STD Torsen Oil _____ K

Tires

Front Type: _____ Compound _____ STD _____ Foam: _____ STD STIFF _____
 Rear Type: _____ Compound _____ STD _____ Foam: _____ STD STIFF _____
 Note: _____

Engine

Type: _____
 Head Clearance _____ .025" Port: _____
 Pipe: _____
 Fuel: _____ %
 Plug _____ Turbo Normal

CLUTCH

Shoe Brand: _____ Compound: _____ ALUM: Blue Red
 Spring Brand: _____ Tension: _____ SILVER HVY 1mm _____
 Gearing: 16T 17T TO 44T 45T
 Note: _____

Clutch Shoes:
 2 Shoes
 3 Shoes
 4 Shoes